



**OFFICE16**



*It is possible to manufacture special sizes and combinations in all references of boards, cork boards and notice showcases existing in this catalogue.*

*Request your budget, we will be very pleased in to attend your requests.*



## ASSEMBLY INSTRUCTIONS

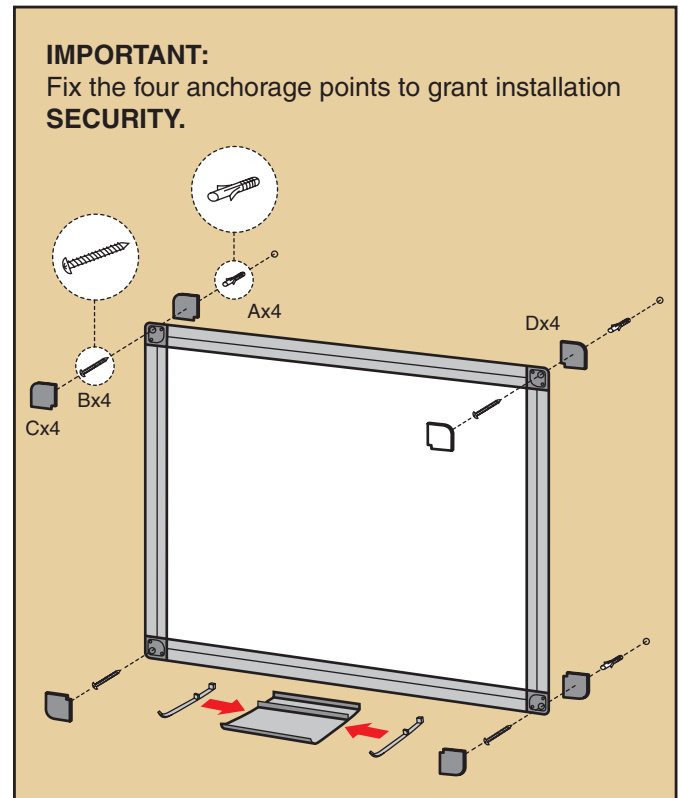
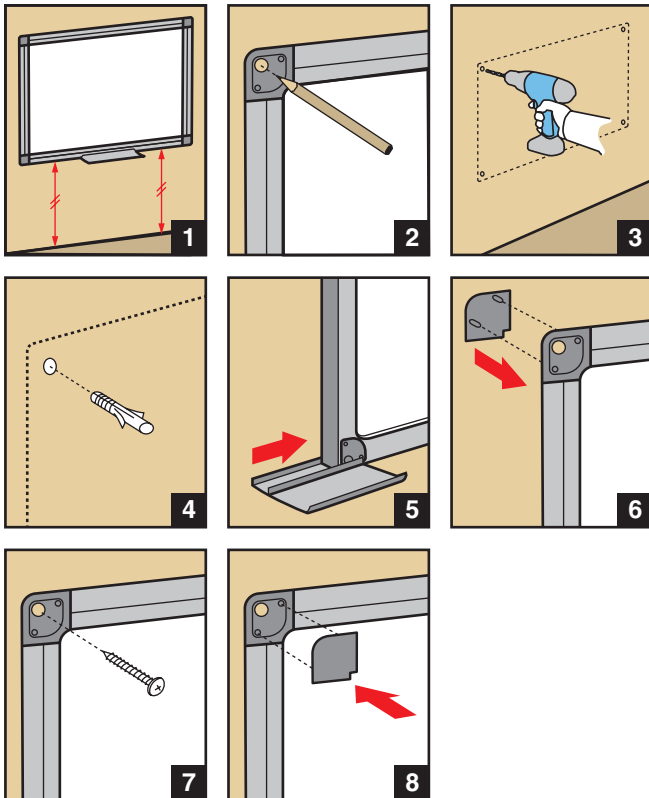

## WRITING SURFACES

As a manufacturers, we believe that our duty is to offer the consumer the widest range possible so that they can choose with criteria to the needs that may arise, in the catalogue we present, you can choose from basic products to the boards with writing surface with 25 years guarantee, always that give them the right treatment.

Usually we fall into the error to contemplate the guarantee in natural years, but this is not correct, what should ensure is the writing time in the board, because what causes their wear surface is the use of it, either by the chalk in the green boards, or the pen tip in the whiteboards, and what which gives them a shorter or longer durability is the surface hardness which translate it in abrasiveness resistance to the writing method.

Following we are pleased to describe you different writing surfaces, so that you can choose the most convenient for the user, and a maintenance recommendations, to prolong the board life.

## REGULATIONS

Existing laws require that all items obey the corresponding regulations, which are normally on a European wide basis, although each country may, whenever it is more restrictive, to adapt them to their needs.

Only an authorised laboratory by government may certify that all products obey existing regulations.

The consumers and the government administration as well may require such attesting documents.

In our catalogue you will find the Standards which certifies the product, in some cases, due to product complexity, their certification requires more than one regulation, which is also reflected.



## BOARDS TO WRITE WITH CHALK

### Painted steel surface

This is obtained by applying paint on a tablex surface, and our recommendation is for sporadic use, a few times a day, for example in hotels, restaurants, industries, or any other sector that doesn't require a frequently use, as in schools.

Its maintenance is very easy; to keep the surface completely clean, just pass a wet cloth in water in order that chalk dust completely disappears.

### Stratified surface

This is obtained by applying melamine resins of high hardness on a Kraft paper which with a treatment of high pressure at high temperature, being crystallized, which results a high resistance surface. We recommend using them by who needs a frequently work, specially designed for its use at schools, universities, where their use is for several hours a day.

Its maintenance is very easy; to keep the surface completely clean, just pass a wet cloth in water in order that chalk dust completely disappears.

In our catalogue you will find two kinds of surface with this finishing, one anti-glare matt and another one with semi-sheen surface that can be chosen depending on their location, the difference between them is the surface finishing. The surface semi-sheen is smoother and permits a better erased from first day, as the edges that we can see with a microscope are less pronounced than in the matt ones. The pronunciation of the edges is what gives them their particular antireflection and more dust can be deposited on them, cleaning is recommended once a day with a wet cloth with water.

### Enamelled steel plate surface

This is obtained by a continuous process of vitrifying a steel sheet at 800°C, with a final result of a very high resistance surface, it allows for the fact to be metallic to use magnets.



## BOARDS TO WRITE WITH DRY MARKERS

We would like to remark that for an excellent erasure the most important is to choose a suitable marker, as unfortunately the markers commercialized in the market have colorants composition that leaves a trace on the surface when the writing is erased.

### Laminated surface

This is obtained by applying melamine resins on an offset white paper through a heat treatment process and then applies this treated paper on a surface that can be chipboard or MDF depending on the surface wanted will be more or less uniform.

We can found within resins different kind of hardness and can be applied on paper with different weight, the final result will be the longevity of surface and the kind of application to which it will be used and its main difference will be the final price of it.

In our catalogue you will find 800's series for very occasional use, for example offices, hotels or for users that requires a board only for using it in meetings, and 11M series in which melamine's used are of higher hardness, even with infrequent use.

Its maintenance is very simple, when you want that all writing traces disappears completely only use some product conceived for their cleaning.

### Stratified surface

This is obtained by applying melamine resins of high hardness on a Kraft paper which with a treatment of high pressure at high temperature, being crystallized, which results a high resistance surface. We recommend using them by who needs a frequently work, specially designed for its use at schools, universities, where their use is for several hours a day.

Its maintenance is very simple, when you want that all writing traces disappears completely only use some product conceived for their cleaning.

### Painted steel surface

This is obtained by applying on a steel surface a special lacquer, which by heat treatment, be crystallized, with a result of a medium hardness surface, for frequent use and it allows using magnets.

Its maintenance is very simple, when you want that all writing traces disappears completely only use some product conceived for their cleaning.

### Enamelled steel plate surface

This is obtained by a continuous process of vitrifying a steel sheet at 800°C, with a final result of a very high resistance surface, it allows for the fact to be metallic to use magnets.

Surface guarantee is reflected in each reference.

Please find below a recommendation table of application depending on use.



REF.	TYPE OF SURFACE	PRIVATE USE	SCHOOL USE	OFFICE USE	UNFREQUENTLY USE	FREQUENT USE	FREQUENTLY USE	WARRANTY USE OF SURFACE
1011	enamelled steel	yes	yes	yes			●	25 years
1R11	enamelled steel	yes	yes	yes	●			25 years
840	painted steel	yes	no	yes		●		10 years
1012	enamelled steel	yes	yes	yes			●	25 years
1013	enamelled steel	yes	yes	yes			●	25 years
1014	enamelled steel	yes	yes	yes			●	25 years
11	stratified	yes	yes	yes			●	10 years
PAB	stratified	yes	yes	yes			●	10 years
11M	laminated	yes	no	yes		●		5 years
800	laminated	yes	no	yes	●			2 years
11I	stratified	yes	yes	yes			●	10 years
PLS	painted	yes	no	yes	●			2 years
PLM	painted	yes	no	yes	●			2 years
PLA	painted	yes	no	yes	●			2 years
11V	stratified	yes	yes	yes			●	5 years
11VS	stratified	yes	yes	yes			●	3 years
11VB	stratified	yes	yes	yes			●	5 years
14	painted	yes	no	yes	●			2 years
14V	stratified	yes	yes	yes			●	5 years
403	painted	yes	no	yes	●			2 years
400	stratified	yes	yes	yes			●	10 years
402	stratified	yes	no	yes		●		5 years
11VPR	stratified	yes	yes	yes			●	5 years
14VCF	stratified	yes	yes	yes			●	5 years
400CF	stratified	yes	yes	yes			●	10 years
11VCF	stratified	yes	yes	yes			●	5 years
11CF	stratified	yes	yes	yes			●	10 years
400P	stratified	yes	yes	yes			●	10 years
14VP	stratified	yes	yes	yes			●	5 years
11P	stratified	yes	yes	yes			●	10 years
11VP	stratified	yes	yes	yes			●	5 years
1011P	enamelled steel	yes	yes	yes			●	25 years
634	painted steel	yes	yes	yes		●		10 years
674	painted steel	yes	yes	yes		●		10 years
624	painted steel	yes	yes	yes		●		10 years
502	painted	yes	no	no	●			2 years
503	painted	yes	no	no	●			2 years
608	painted	yes	no	no	●			2 years
702	painted	yes	no	no	●			2 years
1011IN	enamelled steel	yes	yes	yes			●	25 years
1R11IN	enamelled steel	yes	yes	yes	●			25 years
11IN	stratified	yes	yes	yes			●	10 years
11IIN	stratified	yes	yes	yes			●	10 years
1011D	enamelled steel	yes	yes	yes			●	25 years
11D	stratified	yes	yes	yes			●	10 years
603	stratified	yes	yes	yes		●		10 years

## MAINTENANCE RECOMMENDATIONS FOR WHITE BOARDS

To keep the white boards surface in an excellent condition, it is necessary to clean the surface regularly, if the marker is of good quality, once a day is enough, even if the use is frequent, for to clean them you can use some product that actually are in the market specially developed for this purpose, since all markers always leave a trace that with the time causes a deficient erased.

It is very important also, maintain the eraser as clean as possible, changing the erased surface when it will be full of marker pigment that it absorbs when is doing its function.

## MAINTENANCE RECOMMENDATIONS FOR GREEN BOARDS

To keep the green boards surface in an excellent condition, it is necessary to clean the surface regularly, once a day is enough, even if the use is frequent, for to clean them you can simply use a wet cloth in water and the surface will be completely clean of dust that chalk leaves when is writing.

Also it is very important to keep the eraser as clean as possible, changing or cleaning the erased surface when it is full of dust that it absorbs when is doing its function.



**Ref. 5MEM - MEETING EASEL WITH METALLIC STRUCTURE**

**Surface guarantee: 5 years.**

With frame, laminated surface. Useful to be used with writing pads and dry markers.

The height can be regulated up to 180 cm by telescopic tripod.

**100% Recyclable**

Measures: 70x102 cm - U/pack: individual carton

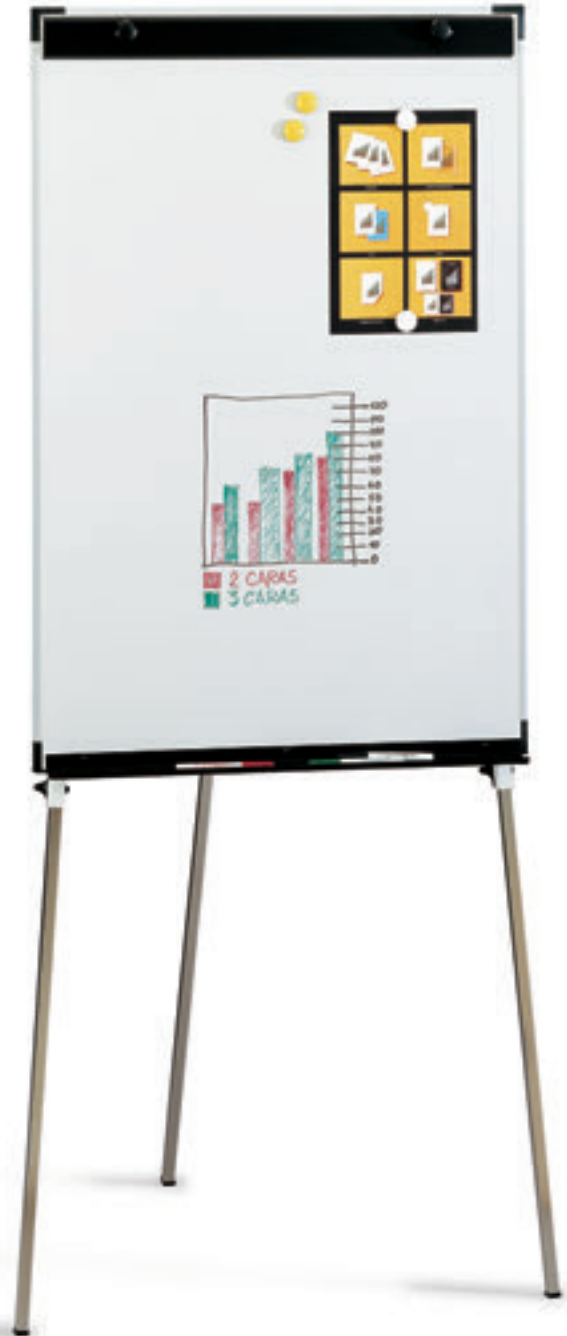

**Ref. 9EM - METALLIC MEETING EASEL WITH METALLIC STRUCTURE**

**Surface guarantee: 5 years.**

With frame, white metal surface, useful to work with magnets, writing pads and dry markers.

The height can be regulated up to 180 cm by telescopic tripod.

**100% Recyclable**

Measures: 70x102 cm - U/pack: individual carton.

It is recommended to do a suitable surface maintenance to keep it in a perfect state of use.



**Ref. 8-1EM - STRATIFIED MEETING EASEL WITH METALLIC STRUCTURE**

**Surface guarantee: 10 years.**

With frame, stratified surface. Useful to be used with writing pads and dry markers.

The height can be regulated up to 180 cm by telescopic tripod.

**100% Recyclable**

Measures: 70x102 cm - U/pack: individual carton.

**Ref. 8-1 - STRATIFIED MEETING EASEL**

**Surface guarantee: 10 years.**

With frame, stratified surface. Useful to be used with writing pads and dry markers.

The height can be regulated up to 180 cm by telescopic tripod.

Adjustable system which gives a great stability, when the three feet are joined forming one unit.

**100% Recyclable**

Measures: 70x102 cm - U/pack: individual carton.



It is recommended to do a suitable surface maintenance to keep it in a perfect state of use.

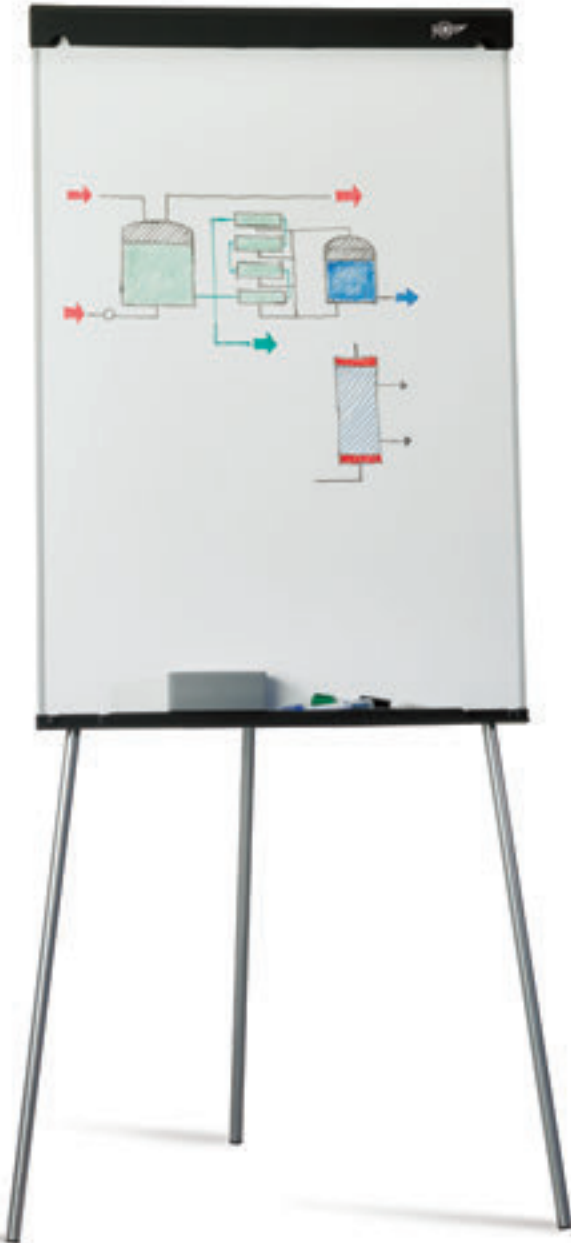

**Ref. 5M - MEETING EASEL**

**Surface guarantee: 5 years.**

With frame, laminated surface. Useful to be used with writing pads and dry markers.

The height can be regulated up to 180 cm by telescopic tripod.

**Ref. 5MS**

Adjustable system which gives a great stability, when the three feet are joined forming one unit.

**100% Recyclable**

Measures: 70x102 cm - U/pack: individual carton.



**Ref. 9**

**METALLIC MEETING EASEL**

**Surface guarantee: 5 years.**

With frame, white metal surface, useful to work with magnets, writing pads and dry markers.

The height can be regulated up to 180 cm by telescopic tripod.

**Ref. 9S**

Adjustable system which gives a great stability, when the three feet are joined forming one unit.

**100% Recyclable**

Measures: 70x102 cm - U/pack: individual carton.



It is recommended to do a suitable surface maintenance to keep it in a perfect state of use.



Ref. 10

**STABILITY SYSTEM**

Stability system to be adapted to new meeting easels Ref. 5M, 8 and 9, adjustable opening that gives a great stability when the three feet are joined forming one unit.



With stability system

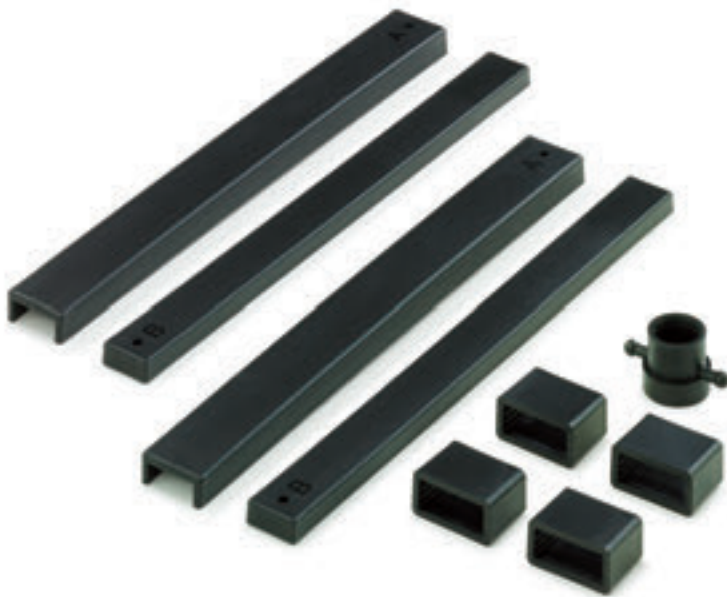

Without stability system



**WRITING PADS**

Bound, with multipunched system.  
Measures: 65x90 cm - **100% Recyclable**

**Ref. BLC-25**

25 plain sheets, flat - U/box: 20

**Ref. BLC-25B**

25 plain sheets, individual bag - U/box: 12

**Ref. BLC-25CB**

25 squared sheets to 25 mm,  
individual bag - U/box: 12

**Ref. BLC-50**

50 plain sheets, flat - U/box: 10

**Ref. BLC-50B**

50 plain sheets, individual bag - U/box: 6



**Ref. 9TR**  
**MEETING EASEL ON WHEELS**

**Surface guarantee: 5 years.**

With frame. Base on wheels, all of them with brake.  
White metal surface to work with dry markers and magnets.  
This system allows the placement of writing pads,  
tray for markers and cleaning pad.

It can be adjusted in three heights, 180, 192 and 204 cm.

**100% Recyclable**

Measures: 70x102 cm - U/pack: individual carton.



**Ref. 9TRM**  
**MEETING EASEL ON WHEELS**

**Surface guarantee: 5 years.**

With frame. Base on wheels, all of them with brake.  
Laminated surface to work with dry markers.  
This system allows the placement of writing pads,  
tray for markers and cleaning pad.

It can be adjusted in three heights, 180, 192 and 204 cm.

**100% Recyclable**

Measures: 70x102 cm - U/pack: individual carton.



It is recommended to do a suitable surface maintenance to keep it in a perfect state of use.

## WHITEBOARDS

With aluminium frame and decorative corners.  
To work with magnets and magnetic figures.  
To write with dry markers.  
Can be placed in horizontal or vertical position.  
**100% Recyclable**

### Ref. 1011

**Surface guarantee: 25 years.**

Enamelled steel plate surface in white colour.  
Supplied with a 40 cm aluminium tray, elements to hang up maps and wall holders.

**Certificated according UNE EN 14434:2010 and UNE 11016:89 Standards**

Measures:

<b>Ref. 1011-1</b> 45 x 60 cm	<b>Ref. 1011-5</b> 122x200 cm
<b>Ref. 1011-2</b> 61 x 100 cm	<b>Ref. 1011-6</b> 122x244 cm
<b>Ref. 1011-3</b> 122x100 cm	<b>Ref. 1011-7</b> 122x300 cm
<b>Ref. 1011-4</b> 122x150 cm	<b>Ref. 1011-8</b> 122x360 cm

U/pack: individual carton.

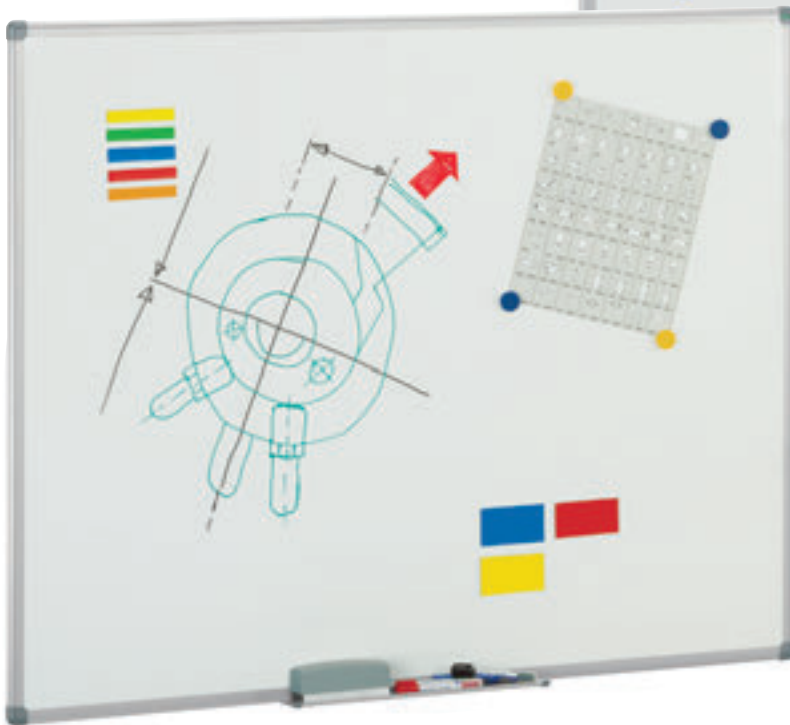
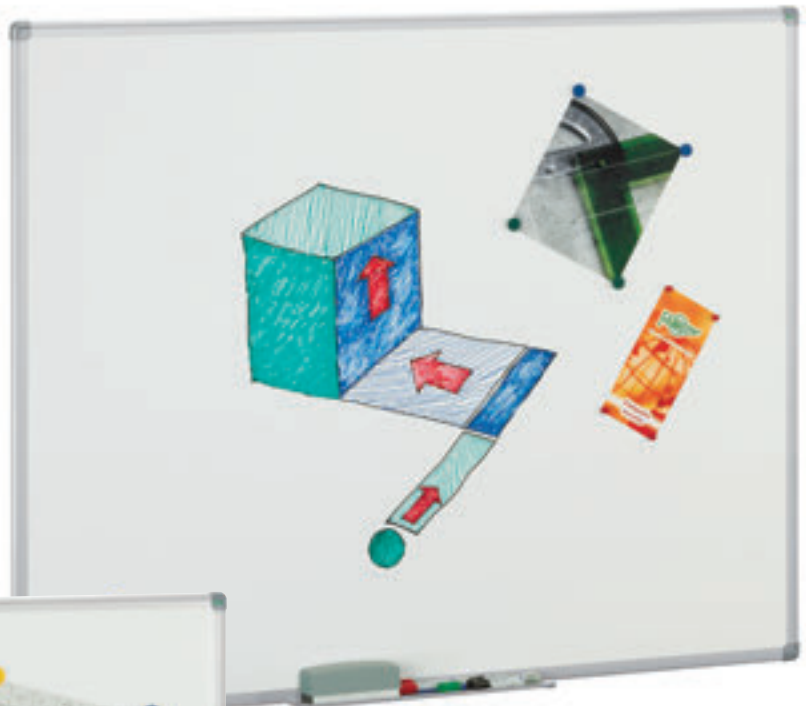

### Ref. 1R11

**Surface guarantee: 25 years.**

**MATT** specially useful for projections.

Enamelled steel plate surface in white colour.

Owing to their matt surface if a high quality marker is not used can leave a line pigment stroke and it requires a frequently surface cleaning.

It allows their writing and erased with whiteboard markers, but their main use is for projections, as their surface is the best to minimize projector reflections. Supplied with a 40 cm aluminium tray, elements to hang up maps and wall holders.

**Certificated according UNE EN 14434:2010 and UNE 11016:89 Standards**

Measures:

<b>Ref. 1R11-3</b> 122x100 cm
<b>Ref. 1R11-4</b> 122x150 cm
<b>Ref. 1R11-5</b> 122x200 cm
<b>Ref. 1R11-6</b> 122x244 cm
<b>Ref. 1R11-7</b> 122x300 cm

U/pack: individual carton.

### Ref. 840

**Surface guarantee: 10 years.**

Painted steel surface.

Supplied with a 30 cm aluminium tray and wall holders.

**Certificated according UNE 11016:89 Standard**

Measures:

<b>Ref. 840-1</b> 45 x 60 cm	<b>Ref. 840-4</b> 120x150 cm
<b>Ref. 840-10</b> 60 x 90 cm	<b>Ref. 840-12</b> 120x180 cm
<b>Ref. 840-11</b> 90 x 120 cm	<b>Ref. 840-5</b> 120x200 cm

U/pack: individual carton.

### Boards prepared for support

Measures:

<b>Ref. 840-11S</b> 90 x 120 cm
<b>Ref. 840-4S</b> 120x150 cm
<b>Ref. 840-12S</b> 120x180 cm
<b>Ref. 840-5S</b> 120x200 cm

U/pack: individual carton.

**It is essential to set the four anchor points, to ensure the installation safety.**

**It is recommended to do a suitable surface maintenance to keep it in a perfect state of use.**

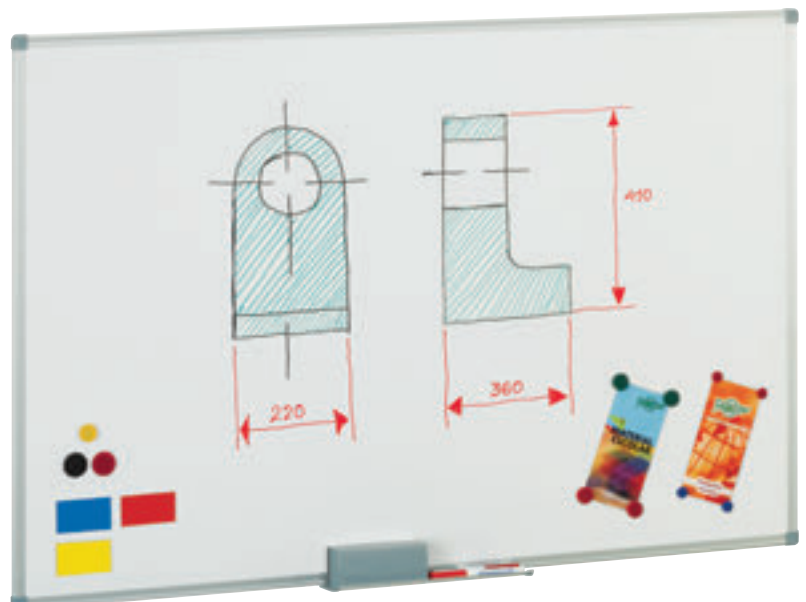

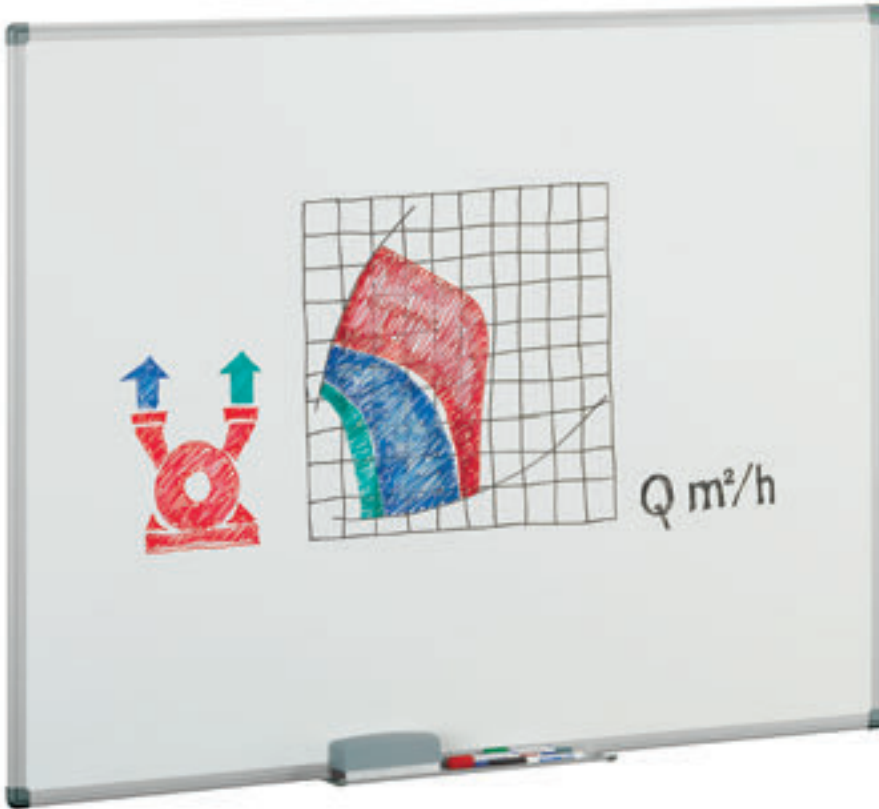

**Ref. 11**

**WALL DRY WHITEBOARDS**

**Surface guarantee: 10 years.**

With aluminium frame and decorative corners.

Stratified plate surface in white colour.

To write with dry markers.

Supplied with a 40 cm aluminium tray, elements to hang up maps and wall holders.

Can be placed in horizontal or vertical position.

**Certificated according UNE EN 14434:2010 and UNE 11016:89 Standards**

**100% Recyclable**

Measures:

**Ref. 11-1** 45 x 60 cm

**Ref. 11-2** 80 x 60 cm

**Ref. 11-3** 122x100 cm

**Ref. 11-4** 122x150 cm

**Ref. 11-5** 122x200 cm

**Ref. 11-6** 122x244 cm

**Ref. 11-7** 122x300 cm

**Ref. 11-8** 122x360 cm

U/pack: individual carton.

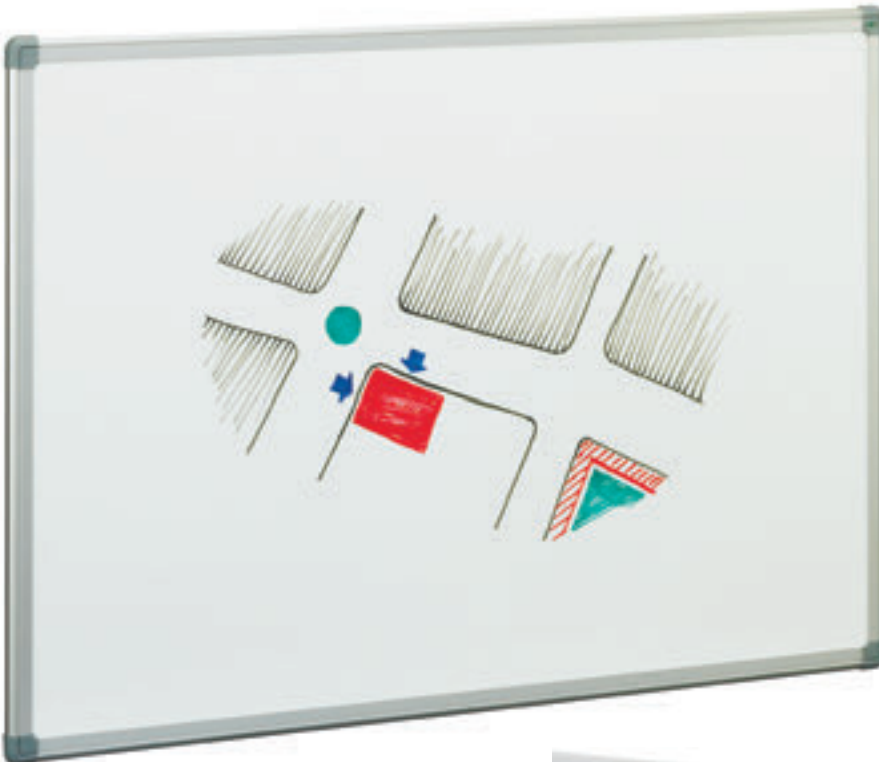

**Ref. PAB**

White stratified surface. Matt rear side,

suitable for projections.

Supplied with wall holders.

Measures:

**Ref. PAB-1** 45x 60 cm

**Ref. PAB-2** 60x 90 cm

**Ref. PAB-3** 75x100 cm

U/pack: individual carton.

**It is essential to set the four anchor points, to ensure the installation safety.**

**It is recommended to do a suitable surface maintenance to keep it in a perfect state of use.**





## WHITEBOARDS

With aluminium frame and decorative corners.  
To write with dry markers.  
Can be placed in horizontal or vertical position.  
**100% Recyclable**

### Ref. 11M

**Surface guarantee: 5 years.**

Laminated surface.  
Supplied with a 40 cm aluminium tray  
and wall holders.

**Certificated according UNE EN 14434:2010  
and UNE 11016:89 Standards**

Measures:

**Ref. 11M-1** 45 x 60 cm

**Ref. 11M-2** 60 x 90 cm

**Ref. 11M-3** 90 x 120 cm

**Ref. 11M-4** 100x150 cm

**Ref. 11M-5** 122x200 cm

**Ref. 11M-6** 122x244 cm

U/pack: individual carton.

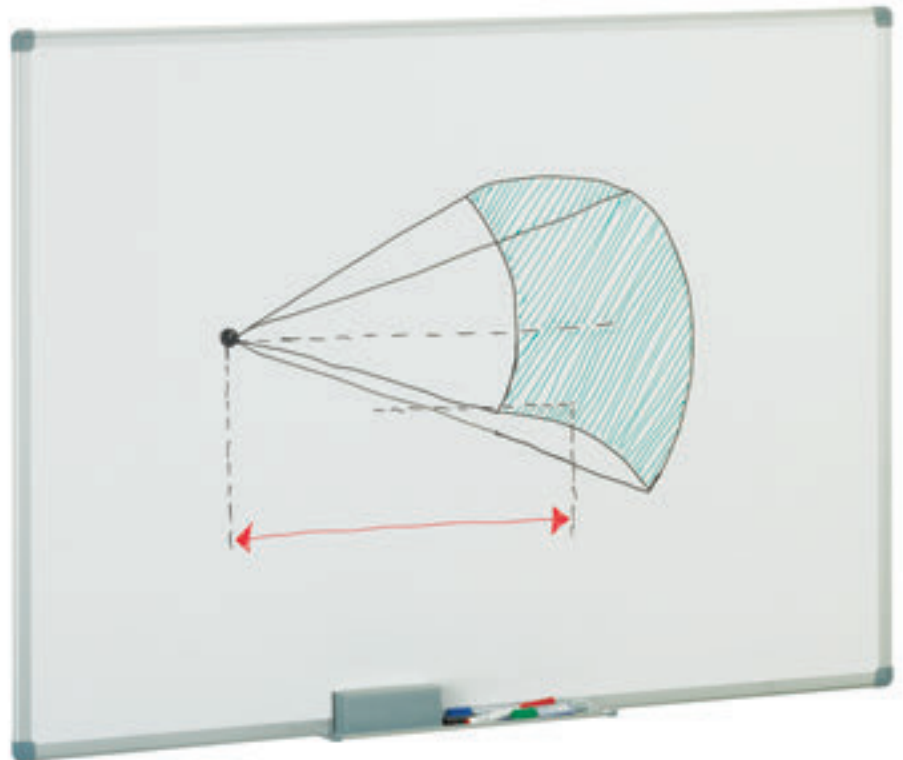

### Ref. 800

**Surface guarantee: 2 years.**

8 mm thickness laminated surface.  
Supplied with a 30 cm aluminium tray  
and wall holders.

**Certificated according  
UNE 11016:89 Standard**

Measures:

**Ref. 800-1** 45 x 60 cm

**Ref. 800-10** 60 x 90 cm

**Ref. 800-11** 90 x120 cm

**Ref. 800-4** 100x150 cm

**Ref. 800-12** 120x180 cm

**Ref. 800-5** 120x200 cm

U/pack: individual carton.



**It is essential to set the four anchor points,  
to ensure the installation safety.**

**It is recommended to do a  
suitable surface maintenance to keep  
it in a perfect state of use.**





## METALLIC PLAN BOARDS

With aluminium frame and decorative corners. Surface printed in two colours.

To be used with magnets as well as with dry markers. Supplied with a 40 cm aluminium tray and wall holders.

**Certificated according  
UNE 11016:89 Standard  
100% Recyclable**

Measures: 60x90 cm  
U/pack: individual carton.

### Ref. PLS - WEEKLY PLAN BOARD

Useful for weekly plans, with daily and hourly grid besides of a large note area at its bottom.



### Ref. PLM - MONTHLY PLAN BOARD

Useful for monthly plans, with weekly and daily grid.



### Ref. PLM - MONTHLY PLAN BOARD

Useful for monthly plans, with weekly and daily grid.

It is essential to set the four anchor points, to ensure the installation safety.

It is recommended to do a suitable surface maintenance to keep it in a perfect state of use.

## GREENBOARDS

With aluminium frame and decorative corners.  
Supplied with a 40 cm aluminium tray,  
elements to hang up maps and wall holders.  
Can be placed in horizontal or vertical position.

**Certificated according UNE EN 14434:2010  
and UNE 11016:89 Standards  
100% Recyclable**

**Ref. 1012**

**Surface guarantee: 25 years.**

Enamelled steel plate surface.

To work with magnets or magnetic figures  
and with chalk.

Measures:

**Ref. 1012-3** 122x100 cm

**Ref. 1012-4** 122x150 cm

**Ref. 1012-5** 122x200 cm

**Ref. 1012-6** 122x244 cm

**Ref. 1012-7** 122x300 cm

**Ref. 1012-8** 122x360 cm

U/pack: individual carton.



**Ref. 11VS**

**Surface guarantee: 3 years.**

Stratified surface in semi-gloss green colour,  
suitable for users that want a good writing rubbing  
even to the detriment of reflect that it involves,  
or whose place was protected from direct light.

Measures:

**Ref. 11VS-3** 122x100 cm

**Ref. 11VS-4** 122x150 cm

**Ref. 11VS-5** 122x200 cm

**Ref. 11VS-6** 122x244 cm

**Ref. 11VS-7** 122x300 cm

U/pack: individual carton.



**It is essential to set the four anchor points,  
to ensure the installation safety.**

**It is recommended to do a  
suitable surface maintenance to keep  
it in a perfect state of use.**



## WHITEBOARDS WITH METALLIC HOLDING

With aluminium frame and decorative corners. To write with dry markers. Grip useful for writing pads. Supplied with metallic holding board kit on wheels, two of them with brake, 40 cm aluminium tray, elements to hang up maps and wall holders.

**Surfaces certificated according UNE EN 14434:2010 Standard**  
**100% Recyclable**

**Ref. 1011-D**

**Surface guarantee: 25 years.**

Enamelled steel plate surface in white colour. Useful to work with magnets and magnetic figures.

Measures:

**Ref. 1011-D3** 122x100 cm

**Ref. 1011-D4** 122x150 cm

U/pack: individual carton.

**Ref. 11-D**

**Surface guarantee: 10 years.**

Stratified white surface.

Measures:

**Ref. 11-D3** 122x100 cm

**Ref. 11-D4** 122x150 cm

U/pack: individual carton.

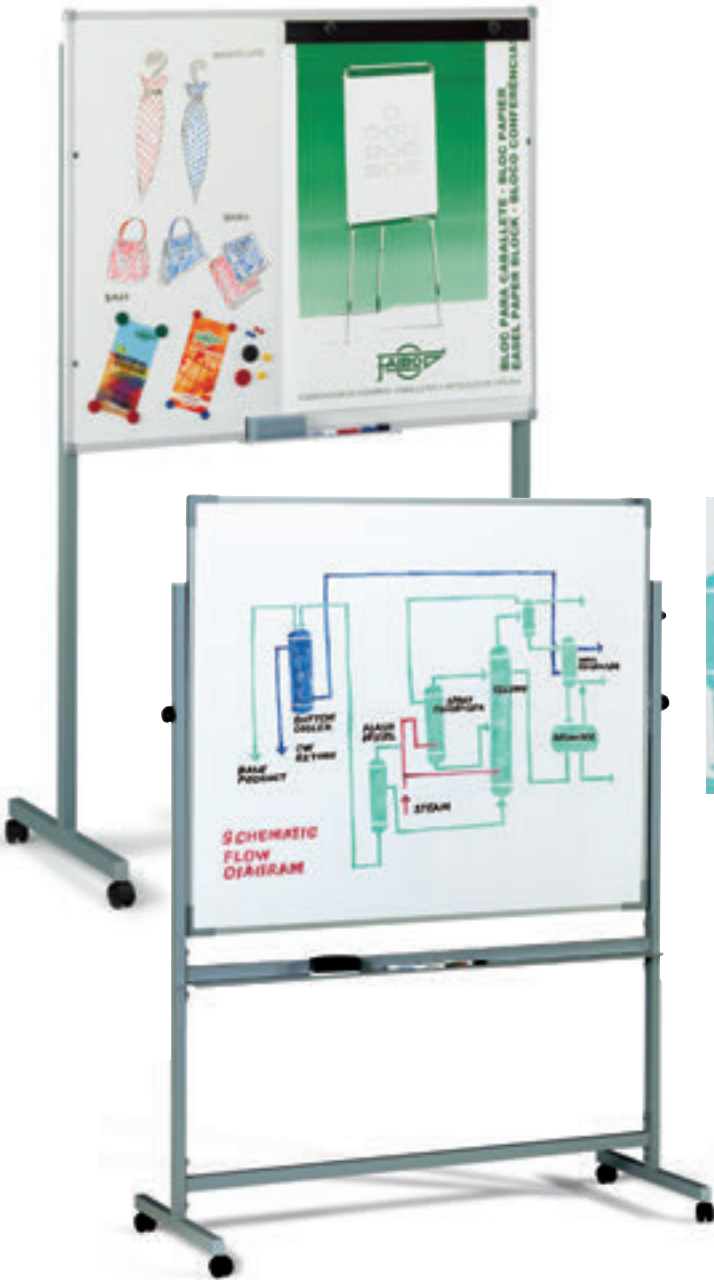

## TORNABLE BOARD

Set containing a holding board kit on wheels, two with brake, 150 cm length aluminium tray and security element. Board of 122x150 cm. with aluminium frame. Two faces useful to work. Supplied with assembly kit. We can produce any combination.

U/pack: individual carton.

**Surfaces certificated according UNE EN 14434:2010 Standard**  
**100% Recyclable**

**Ref. 11/11** - White stratified plate both surfaces.

**Ref. 11/11V** - White stratified plate one surface and green the other one.

**Ref. 11V/11V** - Green stratified plate both surfaces.

**Ref. 11/11P** - White stratified plate both surfaces, one with 5 musical staves.

**Ref. 11V/11VP** - Green stratified plate both surfaces, one with 5 musical staves.

**Ref. 11/1011** - White enamelled steel plate one surface and white stratified the other one.

## Ref. 603

### DOBLE-USE BOARDS

With aluminium frame and decorative corners. One half of the surface in cork and the other half whiteboard. Supplied with a 40 cm aluminium tray and wall holders.

**Certificated according UNE 11016:89 Standard**  
**100% Recyclable**

Measures:

**Ref. 603-2** 60 x 90 cm

**Ref. 603-3** 90 x 120 cm

**Ref. 603-9** 122x183 cm

U/pack: individual carton.



**It is recommended to do a suitable surface maintenance to keep it in a perfect state of use.**





## MAPS OF SPAIN

With aluminium frame and corners for protection.  
Map of Spanish autonomous, published by  
The National Cartography Institute, plasticized surface.  
Supplied with wall holders.

**Certificated according UNE 11016:89 Standard  
100% Recyclable**

**Ref. 141** - To work with pins or drawing pins.  
Measures: 72x93 cm - U/pack: individual carton.

**Ref. 143** - Metal laminated surface, to work with magnets.  
Measures: 72x93 cm - U/pack: individual carton.

## MAPS OF SPAIN, EUROPE AND WORLD

With aluminium frame and corners for protection.  
Metal laminated surface, to work with magnets.  
Supplied with wall holders.

**Certificated according UNE 11016:89 Standard  
100% Recyclable**

**Ref. 153** - Map of Spain and Portugal.  
Measures: 103x129 cm - U/pack: individual carton.  
Supplied with informative leaflet.

**Ref. 163** - Map of Europe.  
Measures: 93x119 cm - U/pack: individual carton.

**Ref. 173** - World Map.  
Measures: 84x140 cm - U/pack: individual carton.

**Maps of laminated surface, rolled in a cardboard tube  
100% Recyclable**

**Ref. 143G** - Spanish autonomous of 72x93 cm

**Ref. 153G** - Spain and Portugal of 103x129 cm

**Ref. 163G** - Europe of 93x119 cm

**Ref. 173G** - World Map of 84x140 cm

**Options:** We can supply different maps by request of  
the customer. We would thank you to ask about possibilities  
and delivery time.

**Note:** These pictures can be changed during the year if  
there is any renewal of the edition.

It is essential to set the four anchor points,  
to ensure the installation safety.



## CORK BOARDS AND CLOTH COVERED CORK BOARDS

With aluminium frame and decorative corners.  
 Supplied with wall holders.  
 Can be placed in horizontal or vertical position.  
 Covered colours: black, grey, blue, crimson, green, ochre.  
**Certificated according UNE 11016:89 Standard**  
**100% Recyclable**

### Ref. 601

4 mm thick cork surface with solid inner plate of 8 mm thickness.

Measures:

<b>Ref. 601-1</b> 50 x100 cm	<b>Ref. 601-5</b> 100x200 cm
<b>Ref. 601-2</b> 60 x 90 cm	<b>Ref. 601-9</b> 120x180 cm
<b>Ref. 601-3</b> 90 x120 cm	<b>Ref. 601-6</b> 122x244 cm
<b>Ref. 601-8</b> 100x100 cm	<b>Ref. 601-7</b> 122x300 cm
<b>Ref. 601-4</b> 100x150 cm	

U/pack: individual carton.

### Ref. 601T

4 mm thick cork surface covered by cloth, with solid inner plate of 8 mm thickness.

To fix all kind of documents by pins or drawing pins.

Measures:

<b>Ref. 601T-2</b> 60x 90 cm
<b>Ref. 601T-3</b> 90x120 cm
<b>Ref. 601T-4</b> 90x150 cm

U/pack: individual carton.

### Ref. 611

2 mm thick cork surface on a 10 mm thick fibre plate.

Measures:

<b>Ref. 611-1</b> 45 x 60 cm
<b>Ref. 611-2</b> 60 x 90 cm
<b>Ref. 611-3</b> 90 x120 cm
<b>Ref. 611-4</b> 100x150 cm

U/pack: individual carton.



### Ref. 611T

Cork surface covered by cloth, with solid inner plate of 10 mm thickness.

Measures:

<b>Ref. 611T-1</b> 45x 60 cm
<b>Ref. 611T-2</b> 60x 90 cm
<b>Ref. 611T-3</b> 90x120 cm
<b>Ref. 611T-4</b> 90x150 cm

U/pack: individual carton.



It is essential to set the four anchor points, to ensure the installation safety.

It is recommended to do a suitable surface maintenance to keep it in a perfect state of use.



Ref. N



Ref. G



Ref. OC



Ref. A



Ref. B



Ref. V



## CORK BOARDS

With aluminium frame and decorative corners.  
 Supplied with wall holders.  
 Can be placed in horizontal or vertical position.  
**Certificated according UNE 11016:89 Standard**  
**100% Recyclable**

### Ref. 820

1 mm thick cork surface with solid fibre inner plate of 7 mm

Measures:

**Ref. 820-1** 45 x 60 cm

**Ref. 820-10** 60 x 90 cm

**Ref. 820-11** 90 x 120 cm

**Ref. 820-4** 120x150 cm

**Ref. 820-12** 120x180 cm

U/pack: individual carton.



It is essential to set the four anchor points, to ensure the installation safety.

## Ref. EXP-PIZ - BOARDS DISPLAY

Comfortable and useful display, containing boards of 23x33 cm in wooden frame and aluminium.  
 Measures: 50x50x185 cm



## Ref. 80 BOARD INSTALLATION KIT 100% Recyclable

Specially designed to make installation easier. It allows to place a board from 90 cm to 120 cm, from ground level every 5 cm and only with a pencil or a punch help to mark wall points where holes will be made later for anchor.  
 Set supplied in a wooden box with handle for transport.

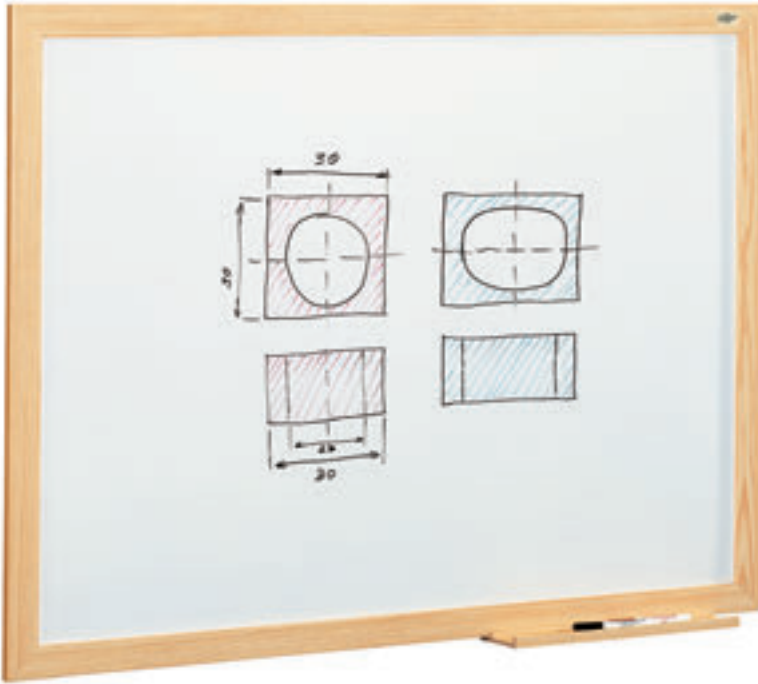

## WHITEBOARDS AND GREENBOARDS

Laminated fibre frame. Supplied with wall holders.  
Measures: 90x120 cm - 100x150 cm  
100x200 cm are supplied with a 40 cm tray.  
Options: Trays in any size.

**Boards marked with (\*), are certificated according UNE EN 14749:06 Standard 100% Recyclable**

### Ref. 400

**Surface guarantee: 10 years.**

White stratified surface. To write with dry markers.

Measures:

<b>Ref. 400-1</b>	40 x 50 cm	<b>Ref. 400-4IND</b>	70 x 95 cm
<b>Ref. 400-2</b>	50 x 60 cm	<b>Ref. 400-5IND</b>	90 x 120 cm
<b>Ref. 400-3</b>	60 x 70 cm	<b>* Ref. 400-6IND</b>	100x150 cm
<b>Ref. 400-4</b>	70 x 95 cm	<b>* Ref. 400-7IND</b>	100x200 cm
<b>Ref. 400-5</b>	90 x 120 cm		U/pack: individual carton.
<b>* Ref. 400-6</b>	100x150 cm		
<b>* Ref. 400-7</b>	100x200 cm		

U/pack: 2 units.



### Ref. 402

**Surface guarantee: 5 years.**

White stratified surface. To write with dry markers.

Measures:

<b>Ref. 402-1</b>	65x 84 cm
<b>Ref. 402-2</b>	80x120 cm
<b>Ref. 402-3</b>	90x130 cm

U/pack: 6 units.

<b>Ref. 402-1IND</b>	65x 84 cm
<b>Ref. 402-2IND</b>	80x120 cm
<b>Ref. 402-3IND</b>	90x130 cm

U/pack: individual carton.

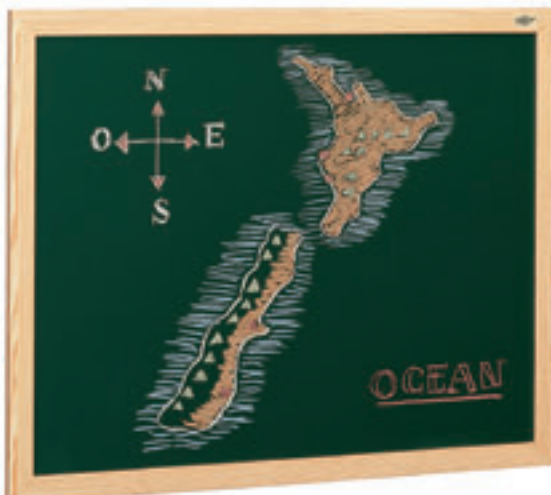

### Ref. 403

**Surface guarantee: 2 years.**

Painted surface. To write with chalk.

Measures:

<b>Ref. 403-1</b>	65 x 84 cm
<b>Ref. 403-2</b>	80 x 120 cm
<b>Ref. 403-3</b>	100x129 cm

U/pack: 6 units.

<b>Ref. 403-1IND</b>	65 x 84 cm
<b>Ref. 403-2IND</b>	80 x 120 cm
<b>Ref. 403-3IND</b>	100x129 cm

U/pack: individual carton.

It is recommended to do a suitable surface maintenance to keep it in a perfect state of use.



## CORK BOARDS

Supplied with wall holders.

**Boards marked with (\*), are certified according UNE EN 14749:06 Standard 100% Recyclable**

### Ref. 600

Laminated fibre frame similar beech wood, 5 mm thick cork surface.

Measures:

<b>Ref. 600-1</b> 60 x 75 cm	<b>Ref. 600-1IND</b> 60 x 75 cm
<b>Ref. 600-2</b> 75 x110 cm	<b>Ref. 600-2IND</b> 75 x110 cm
<b>Ref. 600-5</b> 90 x120 cm	<b>Ref. 600-5IND</b> 90 x120 cm
* <b>Ref. 600-6</b> 100x150 cm	* <b>Ref. 600-6IND</b> 100x150 cm
* <b>Ref. 600-7</b> 100x200 cm	* <b>Ref. 600-7IND</b> 100x200 cm

U/pack: 2 units. U/pack: individual carton.

### Ref. 602

Laminated fibre frame similar pine wood, 5 mm thick cork surface with solid inner plate.

Measures:

<b>Ref. 602-1</b> 60 x 75 cm	<b>Ref. 602-1IND</b> 60 x 75 cm
<b>Ref. 602-2</b> 75 x110 cm	<b>Ref. 602-2IND</b> 75 x110 cm
<b>Ref. 602-5</b> 90 x120 cm	<b>Ref. 602-5IND</b> 90 x120 cm
* <b>Ref. 602-6</b> 100x150 cm	* <b>Ref. 602-6IND</b> 100x150 cm
* <b>Ref. 602-7</b> 100x200 cm	* <b>Ref. 602-7IND</b> 100x200 cm

U/pack: 2 units. U/pack: individual carton.



## INEXPENSIVE CORK BOARDS

Pine wood frame. Supplied with wall holders. **Certificated according EN 71 Standard 100% Recyclable**

### Ref. 607

Bag of pins included.

Measures:

<b>Ref. 607-1</b> 30x 40 cm
<b>Ref. 607-2</b> 40x 60 cm
<b>Ref. 607-3</b> 60x 90 cm
<b>Ref. 607-4</b> 60x120 cm
<b>Ref. 607-5</b> 80x120 cm

U/pack:

30x40 cm - 10 units.

Other measures - 5 units.



### Ref. 646

## SELF-ADHESIVE CORK SHEETS

**100% Recyclable**

Pack 4 self-adhesive cork sheets of 5 mm thickness.

Measures: 300x450 mm

U/carton: 40 packs.



## NOTICE SHOWCASES - 100% Recyclable

Of solid construction with frame of anodized aluminium and decorative corners. Supplied with sliding smooth glassdoors and wall holders. With lock. U/pack: individual carton.

Doors are made in three different materials.

**Glass:** Known as float glass, made off a single 4 mm thick sheet.

**Plexiglass:** Very high transparent plastic, the most similar to glass. Its stiffness and scratch resistance are lower than those of glass but it has higher break resistance.

With an aluminium profile in both sides of doors to give the necessary stiffness.

**This notice showcase is recommended for schools and crowded places due to safely provided against breaking of doors material.**

**Safety glass:** Known as laminated glass, made of two 3 mm thick sheets, with a polyvinyl butiral sheet in-between, which strengthens glass and also prevents glass from splintering in case of breaking. This glass is conforming to EN 12543 Standard.



## SURFACE NATURAL CORK

5 mm thick cork surface stuck on a 10 mm tough wooden base.

### Ref. 604

#### Glassdoors

Measures:

Ref. 604-1 60 x 80 cm

Ref. 604-2 80 x100 cm

Ref. 604-3 90 x120 cm

Ref. 604-4 100x150 cm

### Ref. 614

#### Plexiglas doors

Measures:

Ref. 614-1 60 x 80 cm

Ref. 614-2 80 x100 cm

Ref. 614-3 90 x120 cm

Ref. 614-4 100x150 cm

### Ref. 664

#### Safety glassdoors

Measures:

Ref. 664-1 60 x 80 cm

Ref. 664-2 80 x100 cm

Ref. 664-3 90 x120 cm

Ref. 664-4 100x150 cm

## METALLIC WHITE SURFACE

**Surface guarantee: 10 years.**

Useful to work with magnets or magnetic figures.

To write with dry markers.

### Ref. 624 - Glassdoors

Measures:

Ref. 624-1 60 x 80 cm

Ref. 624-2 80 x100 cm

Ref. 624-3 90 x120 cm

Ref. 624-4 100x150 cm

### Ref. 634 - Plexiglass doors

Measures:

Ref. 634-1 60 x 80 cm

Ref. 634-2 80 x100 cm

Ref. 634-3 90 x120 cm

Ref. 634-4 100x150 cm

### Ref. 674 - Safety glassdoors

Measures:

Ref. 674-1 60 x 80 cm

Ref. 674-2 80 x100 cm

Ref. 674-3 90 x120 cm

Ref. 674-4 100x150 cm

## CORK SURFACE COVERED

5 mm thick cork surface covered by cloth stuck on a 10 mm tough wooden base

### Ref. 604T

#### Glassdoors

Measures:

Ref. 604T-1 60x 80 cm

Ref. 604T-2 80x100 cm

Ref. 604T-3 90x120 cm

### Ref. 614T - Plexiglass doors

Measures:

Ref. 614T-1 60x 80 cm

Ref. 614T-2 80x100 cm

Ref. 614T-3 90x120 cm

### Ref. 664T

#### Safety glassdoors

Measures:

Ref. 664T-1 60x 80 cm

Ref. 664T-2 80x100 cm

Ref. 664T-3 90x120 cm



Ref. N

Ref. G

Ref. OC

Ref. A

Ref. B

Ref. V

It is recommended to do a suitable surface maintenance to keep it in a perfect state of use.

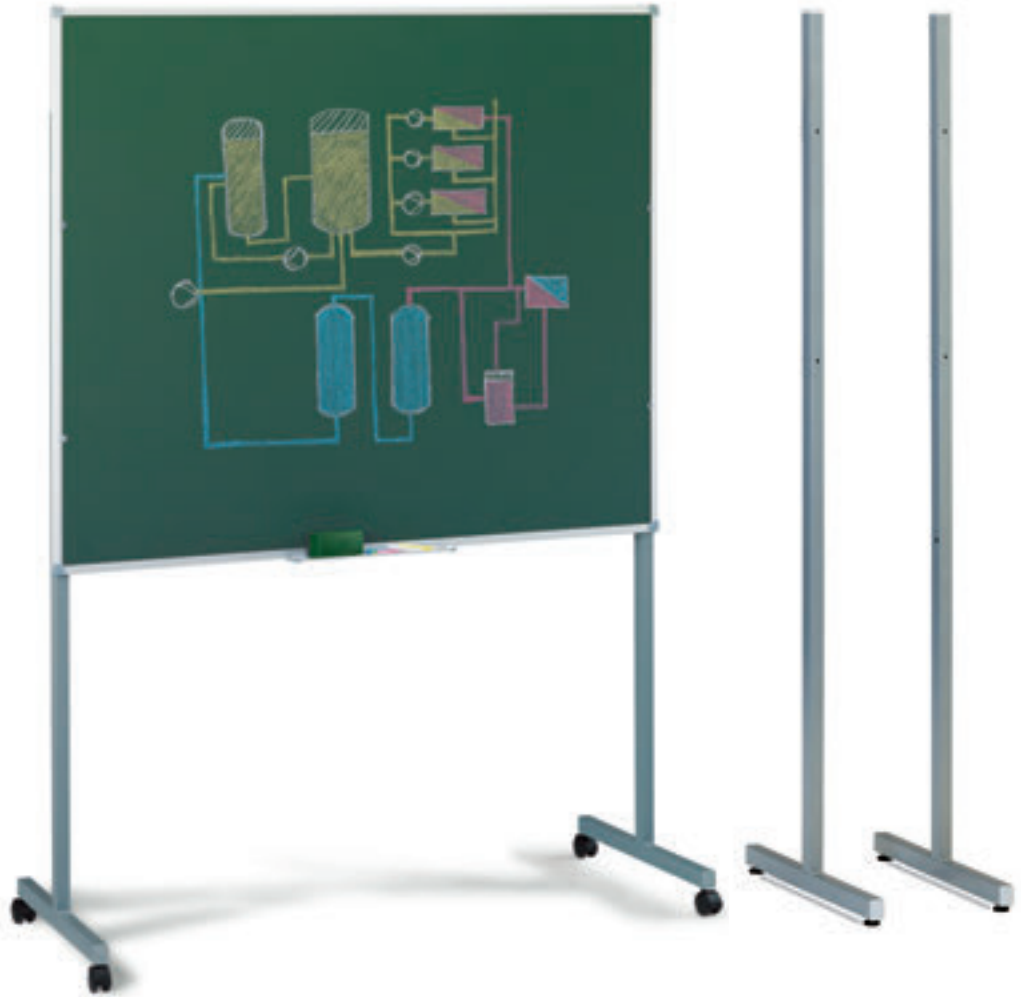

**METALLIC SUPPORTS FOR BOARDS**  
100% Recyclable

**Ref. 18R WITH WHEELS**  
Holding board kit on wheels, two of them with brake and fixing elements.  
Suitable for boards of maximum size of 122x244 cm.  
Measures:  
190 cm height x 60 cm base.  
U/pack: individual carton.

**Ref. 18**  
Support set and holding kit.  
Suitable for boards of maximum size of 122x244 cm.  
Measures:  
190 cm height x 60 cm base.  
U/pack: individual carton.



**BOARD CLEANING PADS**  
100% Recyclable

**Ref. 15**  
Felt greenboard cleaning pad with laminated fibre fingerrip.  
Certificated according EN 71 Standard  
Measures: 8x12x1,6 cm - U/box: 50

**Ref. 15F**  
Felt greenboard cleaning pad with plastic fingerrip.  
Certificated according EN 71 Standard  
Measures: 13,5x5,5x4 cm - U/box: 50



**Ref. 15M**  
Special cleaning pad for whiteboards with plastic fingerrip and 5 spare paper-sheets.  
Certificated according EN 71 Standard  
Measures: 13,5x5,5x4 cm  
U/pack: individual - U/box: 50

**Ref. 15MG - MAGNETIC**  
Special cleaning pad for whiteboards with plastic fingerrip and 5 spare paper-sheets.  
Certificated according EN 71 Standard  
Measures: 13,5x5,5x4 cm  
U/pack: individual - U/box: 50

**SPARE PAPER-SHEETS FOR CLEANING PADS REF. 15M AND 15MG**

**Ref. 15RC**  
5 spare paper-sheets - U/box: 20

**Ref. 15RC10**  
10 spare paper-sheets - U/box: 10

**Ref. 15RC100**  
Box containing 100 spare paper-sheets.





## MODULAR PARTITION SUPPORT FOR SCREENS AND BOARDS Certificated according UNE EN 14434:2010 Standard

Designed only for recommended boards (See section: Boards and cork boards recommended for Ref.13/130 support). You can adapt any other board on demand.

Due to easy assembly, it allows to perform quickly the desired atmosphere. It allows placing boards or cork boards, horizontally or vertically. You can adjust the height very simple and easily, only sliding the chosen unit in the support guides. Support size 1950 mm. height, silver anodized aluminum, with metal base of 350 or 500 mm diameter and 6 mm thick, painted in grey colour.

Supplied with assembling elements and for to adjust the screen height.

Optionally you can install wheels for easy movement.

The base Ref. 13-35 and 130-35 are suitable for boards with maximum length of 150 cm.

The base Ref. 13-50 and 130-50 are suitable for boards with maximum length of 244 cm.

Individual box.

**Ref. 13-35** - Set of one support and one base of 350 mm.

**Ref. 13-50** - Set of one support and one base of 500 mm.

**Ref. 130-35** - Set of two supports and two bases of 350 mm.

**Ref. 130-50** - Set of two supports and two bases of 500 mm.

**Ref. 130-35R** - Set of two supports and two bases of 350 mm.

With three wheels with brakes.

**Ref. 130-50R** - Set of two supports and two bases of 500 mm.

With three wheels with brakes.

## BOARDS AND CORK BOARDS RECOMMENDED FOR SUPPORT REF. 13/130

**Ref. 11M-4** - White board, with aluminium frame. Size 100x150 cm

**Ref. 601CO-4** - Cork board, with aluminium frame. Size 100x150 cm

**Ref. 612CO-4** - Two sides natural cork board, with aluminium frame. Size 100x150 cm

## CLOTH COVERED CORK BOARDS, WITH ALUMINIUM FRAME. SIZE 90x150 cm

**Ref. 601TCO-4A** - Blue cloth

**Ref. 601TCO-4B** - Crimson cloth

**Ref. 601TCO-4N** - Black cloth

**Ref. 601TCO-4G** - Grey cloth

**Ref. 601TCO-4V** - Green cloth

**Ref. 601TCO-4OC** - Ochre cloth

## CLOTH COVERED, TWO SIDES CORK BOARDS, WITH ALUMINIUM FRAME. SIZE 100x150 cm

**Ref. 612TCO-4A** - Blue cloth

**Ref. 612TCO-4B** - Crimson cloth

**Ref. 612TCO-4N** - Black cloth

**Ref. 612TCO-4G** - Grey cloth

**Ref. 612TCO-4V** - Green cloth

**Ref. 612TCO-4OC** - Ochre cloth.



## PLASTIC PAPER-TRAYS

**Certificated according EN 71 Standard - 100% Recyclable**

Piling up trays, vertically or in a stair-way.

### Ref. 93

Made of polystyrene.

With label holder. Measures: 350x250x65 mm

Solid colours: black 02, red 03, green 04, yellow 05, blue 07, grey 08, beige 10, crimson 13.

Transparent colours: clear 23, black 59.

Fluorescent colours: orange 18, green 19,

yellow 20, blue 22, dark blue 52, red 53,

violet 58 - U/carton: 10/unicolour

**Ref. 93-00** - Box with 10 plastic paper-trays in solid assorted colours.

U/carton: 1

**Ref. 93-99** - Box with 10 plastic paper-trays in fluorescent assorted colours.

U/carton: 1

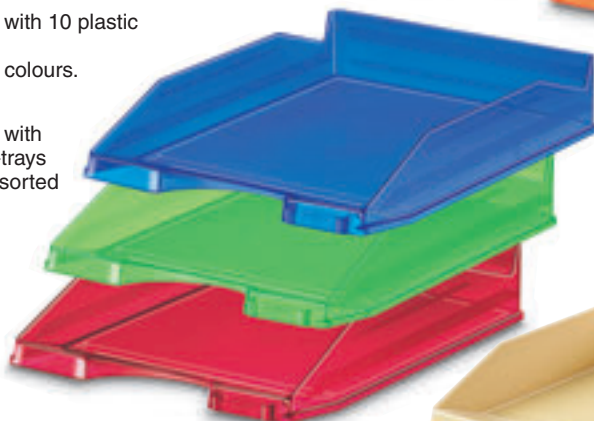
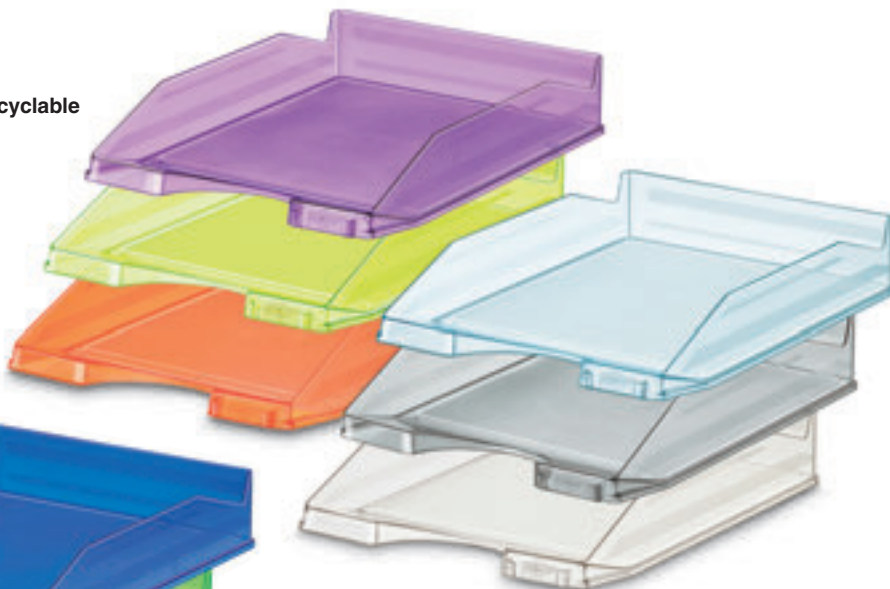

## Ref. 91 - KIT OF PLASTIC RISERS FOR PAPER-TRAYS

Practical and functional system composed of two risers, which allow to increase the capacity to file and stopping that documents can slide to the outer.

Colour: black 02.

Supplied in individual bag.



### Ref. 93TR

Made of translucent polystyrene.

With label holder - Measures: 350x250x65 mm

Colours: orange 61, dark blue 62, red 63, yellow 64, violet 68, green 69 - U/carton: 10/unicolour.

### Ref. 93TR-99

Box with 10 plastic paper-trays in translucent assorted colours - U/carton: 1



WE WOULD THANK YOU INFORM US ABOUT THE COLOUR CODE TOGETHER PRODUCT REFERENCE



**Ref. 104 - Certificated according EN 71 Standard  
100% Recyclable**

Piling up trays between them and by iron risers which allow to increase the capacity to file. Made of polypropylene.  
Measures: 340x250x65 mm. Colours: black 02, red 03, green 04, blue 07, grey 08, beige 10 - U/carton: 10/unicolour.

**Ref. 103-4** - Set 4 iron risers for Ref. 103 and 104.

**PLASTIC PAPER-TRAYS  
100% Recyclable**

Piling up trays, vertically or in a stair-way.

**Ref. 95**

Made of polystyrene. With label holder.  
Measures: 350x250x65 mm  
Solid colours: black 02, red 03, green 04, blue 07, grey 08, beige 10.  
Transparent colours: clear 23, topaz 25.  
U/carton: 10/unicolour

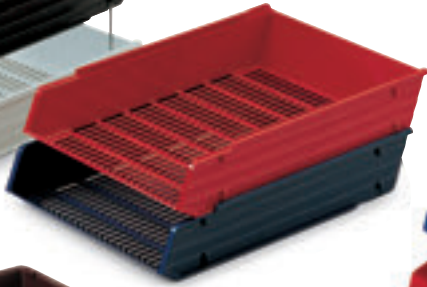

**Ref. 90  
Certificated according EN 71 Standard  
100% Recyclable**

Made of polystyrene. With label holder.  
Piling up trays, vertically, in a stair-way, on right or left side.  
Measures: 340x275x65 mm. Colours: black 02, red 03, green 04, blue 07, grey 08, brown 09.  
U/carton: 10/unicolour.

**Ref. 1020 - KIT OF TWO  
PAPER-TRAYS  
WITH FOUR IRON RISERS  
100% Recyclable**

Piling up trays with iron risers.  
Made of polystyrene.  
Measures: 360x260x65 mm.  
Colours: black 02, red 03, green 04, blue 07, grey 08.  
U/carton: 6/unicolour.

**Ref. 100-4** - Set 4 iron risers for Ref. 1020.

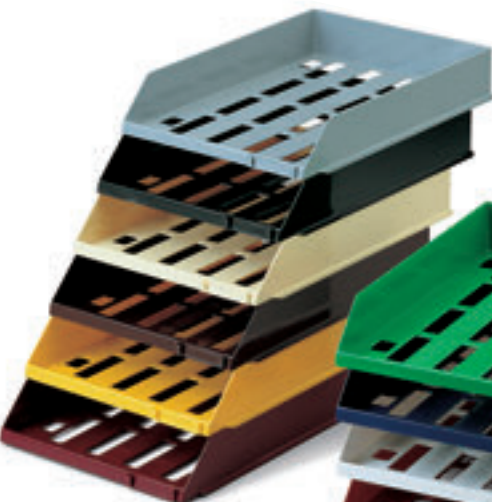
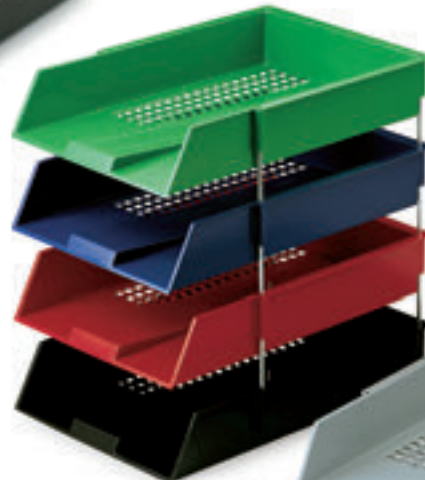

**Ref. 99 - 100% Recyclable**

Made of polystyrene.  
With label holder.  
Measures: 350x250x60 mm  
Colours: white 01, black 02, red 03, green 04, yellow 05, blue 07, grey 08, brown 09, beige 10, crimson 13.  
U/carton: 10/unicolour.

WE WOULD THANK YOU INFORM US ABOUT THE COLOUR CODE TOGETHER PRODUCT REFERENCE



## BOX WITH DRAWERS FOR DOCUMENTS

100 % Recyclable

Individual box.



In polystyrene. Box with drawers of 2,5 and 5 cm for documents, with locking system to avoid the going out of the drawer. With label holder in each drawer. Designed to be stacked vertically forming a solid block.

**Supplied assembled.**

Outside measures: 285x375x230 mm  
Colours: black 02, grey 08.

**Ref. 1006** - 2 drawers of 5 cm and 4 of 2,5 cm

**Ref. 1008** - 8 drawers of 2,5 cm

In polystyrene.  
Box with four drawers of 5 cm for documents, with locking system to avoid the going out of the drawer. With label holder in each drawer. Designed to be stacked vertically forming a solid block.  
Outside grey colour.  
Outside measures:  
285x375x230 mm  
Solid drawers: black 02, red 03, blue 07, grey 08.  
Fluorescent drawers: green 19, dark blue 52, red 53, violet 58.

**Ref. 1000** - Supplied disassembled to reduce storage and transport.

**Ref. 1000M** - Supplied assembled.



WE WOULD THANK YOU INFORM US ABOUT THE COLOUR CODE TOGETHER PRODUCT REFERENCE

## Ref. 150 - PLASTIC MAGAZINE RACK

**Certificated according EN 71 Standard - 100% Recyclable**

Made of polystyrene - Measures: 320x245x75 mm  
 Solid colours: black 02, green 04, blue 07, grey 08, crimson 13.  
 Transparent colours: clear 23, black 59.  
 Fluorescent colours: orange 18, green 19, yellow 20, blue 22,  
 dark blue 52, red 53, violet 58 - U/carton: 10/unicolour



**Ref. 150-00** - Box with 10 plastic magazine rack in solid assorted colours - U/carton: 1  
**Ref. 150-99** - Box with 10 plastic magazine rack in fluorescent assorted colours - U/carton: 1



## PLASTIC OFFICE DESK TIDY 100% Recyclable

Of 78 mm ø and 10 cm height.

### Ref. 205

Made of polystyrene.  
 Solid colours: black 02, red 03, blue 07, grey 08.  
 Transparent colours: clear 23, black 59.  
 Fluorescent colours: orange 18, green 19, yellow 20, blue 22,  
 dark blue 52, red 53, violet 58 - U/carton: 10/unicolour

**Ref. 205-00** - Box with 10 plastic office desk tidy in solid assorted colours - U/carton: 1

**Ref. 205-99** - Box with 10 plastic office desk tidy in fluorescent assorted colours - U/carton: 1

## POLYPROPYLENE PLASTIC DESK TIDY 100% Recyclable

Colours: black 02, red 03, green 04, blue 07, grey 08.  
 U/carton: 30/unicolour

**Ref. 200** - 6 Tubes.

**Ref. 203** - 4 Departments.



WE WOULD THANK YOU INFORM US ABOUT THE COLOUR CODE TOGETHER PRODUCT REFERENCE



**PLASTIC WASTEPAPER BINS AND POLYPROPYLENE COMPLEMENTS**  
**Certificated according EN 71 Standard**  
**100% Recyclable**

**Ref. 305**

Measures: Ø280x310 mm - Capacity: 14 l.  
 Colours: black 02, green 04, yellow 05, blue 07, grey 08, crimson 13.  
 U/carton: 20/unicolour.

**Ref. 305-00**

Box with 6 plastic wastepaper bins in solid assorted colours.  
 U/carton: 1

**Ref. 305TR**

Measures: Ø280x310 mm - Capacity: 14 l.  
 Solid plastic wastepaper bins.  
 Made of polypropylene.  
 Translucent colours: orange 18, green 19, blue 22 - U/carton: 20/unicolour.

**Ref. 305TR-99** - Box with 6 plastic wastepaper bins in translucent assorted colours - U/carton: 1



**Ref. 318**

Hardness wastepaper bin.  
 Measures: Ø325x305 mm  
 Capacity: 18 l.  
 Colours: black 02, green 04, yellow 05, blue 07, grey 08, beige 10, crimson 13.  
 U/carton: 20/unicolour.

**Ref. 317**

Black ring to hold the rubbish bag in the wastepaper bin ref. 318.  
 U/carton: 20/unicolour.

**Ref. 320**

Recycling containers adaptable to wastepaper bin ref. 318.  
 Colours: red 03, green 04, yellow 05, brown 09.  
 Measures: 280x200x100 mm  
 U/carton: 12

**Ref. 319**

Wastepaper bin ref. 318 with containers for recycling. In blue colour, very resistant, capacity 18 l. Supplied with four recycling containers which allow recycling different waste products: paper (blue), metal and plastic (yellow), glass (green), organic waste (brown) and batteries (red) - U/carton: 1

**Ref. 307 - Lattice**

Measures: Ø275x295 mm  
 Capacity: 12 l.  
 Colours: black 02, green 04, blue 07, grey 08, crimson 13.  
 U/carton: 30/unicolour.

**Ref. 307-00** - Box with 10 plastic wastepaper bins in solid assorted colours - U/carton: 1

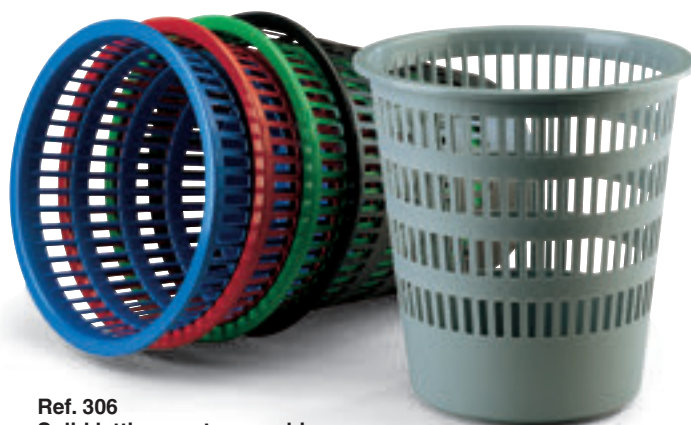

**Ref. 306**

**Solid lattice wastepaper bin**  
 Measures: Ø315x310 mm - Capacity: 16 l.  
 Colours: black 02, green 04, blue 07, grey 08, brown 09, crimson 13.  
 U/carton: 20/unicolour.

WE WOULD THANK YOU INFORM US ABOUT THE COLOUR CODE TOGETHER PRODUCT REFERENCE





### RECYLINE series

Made of recycled and recyclable plastic material, specially designed to be respectful with to the environment, natural resources sustainability and CO2 saving.

100% Recyclable

#### PAPER TRAYS

Ref. 93R2 - black colour.  
Measures: 350x250x65 mm  
U/carton: 10.

#### MAGAZINE RACKS

Ref. 150R2 - black colour.  
Measures : 320x245x75 mm  
U/carton: 10

#### DESK TIDIES

Ref. 205R2 - black colour.  
Measures: Ø78x100 mm  
U/carton: 10.

#### WASTEPAPER BINS

Ref. 307R2 - black colour.  
Measures: Ø275x295 mm  
U/carton: 30

#### BOX 4 DRAWERS

Ref. 1000R2 - black colour.  
Measures: 285x375x230 mm  
U/carton: 1



### CARDBOARD TUBES WITH PLASTIC COVERS

100% Recyclable

Ref. 950-1 - 460 mm length and Ø40 mm  
U/bag: 12

Ref. 950-2 - 460 mm length and Ø60 mm  
U/bag: 10

Ref. 950-3 - 640 mm length and Ø60 mm  
U/bag: 10

Ref. 950-4 - 640 mm length and Ø80 mm  
U/bag: 6

Ref. 950-5 - 750 mm length and Ø80 mm  
U/bag: 6

Ref. 950-6 - 1100 mm length and Ø80 mm  
U/bag: 6

### PLAN-CARRIER ZOOM TUBE

Certificated according EN 71 Standard  
100% Recyclable

Measures: from 400 up to 750 mm  
Diameter: 65 mm

Colours: black 02, red 03, green 04,  
blue 07, grey 08 - U/carton: 50

Ref. 755 - NO HOLDING BAND  
Ref. 755B - WITH HOLDING BAND



WE WOULD THANK YOU INFORM US ABOUT THE COLOUR CODE TOGETHER PRODUCT REFERENCE

**PLASTIC HOLDER FOR DESK DIARIES**  
**100% Recyclable**

Measures: 190x160x33 mm

**Ref. 98**

**Plastic holder for desk diaries with iron rings.**

Solid colours: black 02, blue 07.

Transparent colours: blue 22, clear 23.

Individual box - U/carton: 50

**Ref. 98PE**

**Plastic holder for desk diaries with plastic rings.**

Solid colours: black 02, red 03,

blue 07, grey 08.

Individual bag.

U/carton: 20

**Ref. 98G** - Set of two iron rings.



**LAMINATED FIBRE HOLDER FOR DESK DIARIES WITH IRON RINGS**  
**100% Recyclable**

Measures: 193x154x34 mm

**Ref. 97BNAT - SIMILAR OAK WOOD**

Natural varnished.

Individual box.

U/carton: 50

**Ref. 97BNEG - BLACK**

Black varnished.

Individual box.

U/carton: 50

**Ref. 97BNB**

**SIMILAR OAK WOOD**

Natural varnished.

Individual bag.

U/carton: 44



**Ref. 181 - EURO COIN TRAY**  
**100% Recyclable**

Plastic tray to classify euro coins, with 8 departments, one for each coin value.

Supplied in individual box.

Measures: 310x185x30 mm

Colours: blue 07, grey 08.

WE WOULD THANK YOU INFORM US ABOUT THE COLOUR CODE TOGETHER PRODUCT REFERENCE





## ADHESIVE MAGNETIC STRIPS

Certificated according EN 71 Standard  
100% Recyclable

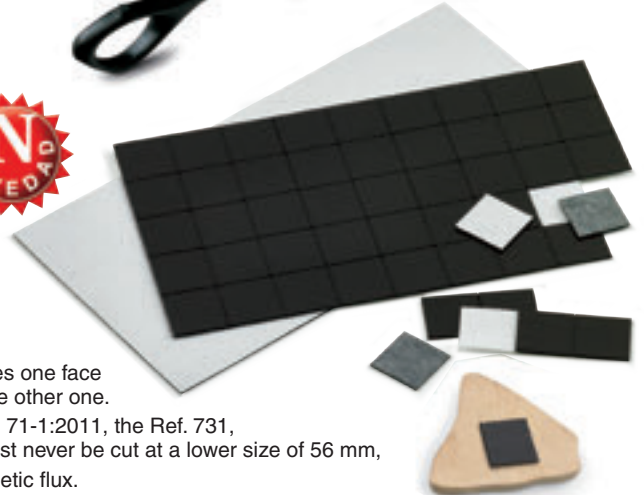

Magnetized tapes one face and adhesive the other one.

According to EN 71-1:2011, the Ref. 731, 733 and 758 must never be cut at a lower size of 56 mm, due to the magnetic flux.

Ref 757 can be cut to any size. The Ref. of 1 mm thickness, and 10 cm length can be hold to 200 grs.

The Ref. of 1,5 mm thickness, and 10 cm length can be hold to 300 grs.

**Ref. 731**  
Measures: 1000x20x1,5 mm

**Ref. 731-10**  
10 strips of 100x20x1,5 mm

**Ref. 733**  
Measures: 3000x20x1,5 mm

**Ref. 758-30**  
10 strips of 300x20x1,5 mm

**Ref. 757-1**  
Measures: 1000x20x1 mm

**Ref. 757-10**  
10 strips of 100x20x1 mm

**Ref. 757-3**  
Measures: 3000x20x1 mm

**Ref. 757-30**  
10 strips of 300x20x1 mm

## ADHESIVE MAGNETIC SHEETS

Certificated according EN 71 Standard - 100% Recyclable

Sheet with 50 pre-cut adhesive magnets of 20x20 mm.

**Ref. 777** - Supplied in individual bag.

**Ref. 778** - Supplied in "Self-Service" bag type.

## Ref. 759

Certificated according EN 71 Standard  
100% Recyclable

Set of 5 cutout magnetized sheets, blue, red, green, yellow and white colour.

Measures: 100x200x0,7 mm - U/box: 10

## ROUND MAGNETS - 100% Recyclable

### Ref. 56

Measures:

**Ref. 56-10** 10 mm

U/Bag: 20

**Ref. 56-20** 20 mm

U/Bag: 20

**Ref. 56-30** 30 mm

U/Bag: 20

**Ref. 56-40** 40 mm

U/Bag: 10

### Ref. 60

Measures:

**Ref. 60-10** 10 mm

Blister 6 u.

**Ref. 60-20** 20 mm

Blister 4 u.

**Ref. 60-30** 30 mm

Blister 3 u.

**Ref. 60-40** 40 mm

Blister 2 u.

Measures of 10, 20, 30 mm available in colours: white 01, black 02, red 03, green 04, yellow 05, blue 07.

Measure of 40 mm available in colours: white 01, black 02, red 03, blue 07.







**OFFICE SCISSORS**  
100% Recyclable

Stainless steel scissors.  
Symmetrical grips.

Supplied in blister - U/box: 10  
Ref. A21 - 21 cm scissors



**PROFESSIONAL SCISSORS**  
100% Recyclable

Stainless steel scissors.  
Grips bi-materials, yielding and smooth inner part. Adjustable cut through a screw.

Supplied in blister - U/box: 10  
Ref. S16 - 16 cm scissors  
Ref. S21 - 21 cm scissors  
Ref. S26 - 26 cm scissors



**SPECIAL OFFICE SCISSORS FOR LEFT-HANDERS**  
100% Recyclable

Stainless steel scissors, blunt point blade and finger grip plastic handles.

Supplied in blister - U/box: 10  
Ref. T321 - 21 cm scissors



Supplied in blister - U/box: 10

Ref. T16 - 16 cm scissors

Ref. T21 - 21 cm scissors

Ref. T25 - 25 cm scissors

Supplied in plastic bag - U/box: 10

Ref. T1600 - 16 cm scissors

Ref. T2100 - 21 cm scissors

Ref. T2500 - 25 cm scissors

**OFFICE SCISSORS**  
Certificated according  
EN 71 Standard - 100% Recyclable

Stainless steel scissors, blunt point blade and finger grip plastic handles.



**ALUMINIUM PENCIL SHARPENERS**  
Certificated according EN 71 Standard  
100% Recyclable

Ref. 2001 - Bevel shape - U/box: 24

Ref. 2002 - Rectangular shape - U/box: 24

Ref. 2003 - Bevel shape, double use - U/box: 12

Supplied in blister

Ref. 2501 - Bevel shape - U/box: 24

Ref. 2502 - Rectangular shape - U/box: 24

Ref. 2503 - Bevel shape, double use - U/box: 24

**METALLIC PENCIL SHARPENERS**

High-quality cutting blade.

100% Recyclable

Ref. 1001 - Bevel shape - U/box: 24

Ref. 1002 - Rectangular shape - U/box: 24

Ref. 1003 - Bevel shape, double use - U/box: 12



**MADE OF METHYL METHACRYLATE  
MECHANIZED AND RECTIFIED,  
HIGH PRECISION  
100% Recyclable**

Transparent colours: clear T and green V.  
Supplied in "Self-service" bag type.

**Ref. 101 - NON GRADUATED  
SQUARES OF 45° AND 60°**

2 mm thickness - U/box: 10  
Lengths/cm: 15, 20, 25, 30, 35, 40, 45, 50.

**Ref. 102 - GRADUATED BY THERMO-PRINTING  
SQUARES OF 45° AND 60°**

2 mm thickness - U/box: 10  
Lengths/cm: 15, 20, 25, 30, 35, 40.

All references 101 and 102 are available  
with border.



**PROTRACTORS**

Centesimal graduation of (100°)  
and sexagesimal of (90°).

**Ref. 109 - BEVELLED PROTRACTORS OF 360°**

Lengths/cm: 10, 15, 20 - U/box: 10

**Ref. 111 - BEVELLED RECTANGULAR  
PROTRACTORS FOR NAUTICAL,  
PURPOSES**

Lengths/cm: 15, 20 - U/box: 10

**Ref. 106 - BEVELLED GRADUATED  
BY THERMO-PRINTING RULERS OF 2 mm  
THICKNESS**

Lengths/cm: 30, 40, 50, 60, 80, 100 - U/box: 10

**Ref. 108 - BEVELLED GRADUATED  
BY THERMO-PRINTING RULERS  
OF 4 mm THICKNESS**

Lengths/cm: 30, 40, 50, 60, 80, 100 - U/box: 6

References 106 and 108 are supplied  
in "Self-service" bag type.

**REDUCTION TRIANGULAR SCALES  
100% Recyclable**

Supplied in "Self-service" bag type  
U/box: 20.

**Ref. 275E - 30 cm**

**Ref. 275 - 30 cm with three coloured  
grooves.**

Scales: 1:100, 1:200, 1:250, 1:300, 1:400, 1:500

**Ref. 275-10 - 10 cm with three coloured  
grooves.**

**Ref. 275-15 - 15 cm with three coloured  
grooves.**

Scales: 1:100, 1:200, 1:300, 1:400, 1:500, 1:600

**Ref. 275-CAJ**

Plastic box for reduction scales of 30 cm



WE WOULD THANK YOU INFORM US ABOUT THE  
COLOUR CODE TOGETHER PRODUCT REFERENCE



## HIGH QUALITY ALUMINIUM RULERS FOR CUTTING

Supplied in "Self-service" bag type - U/box: 10  
High precision rulers with stainless steel cylindrical edge special to be used for cutting and with a rubber band non-slippery.

- Ref. 960-40 - Ruler 40 cm
- Ref. 960-60 - Ruler 60 cm
- Ref. 960-80 - Ruler 80 cm

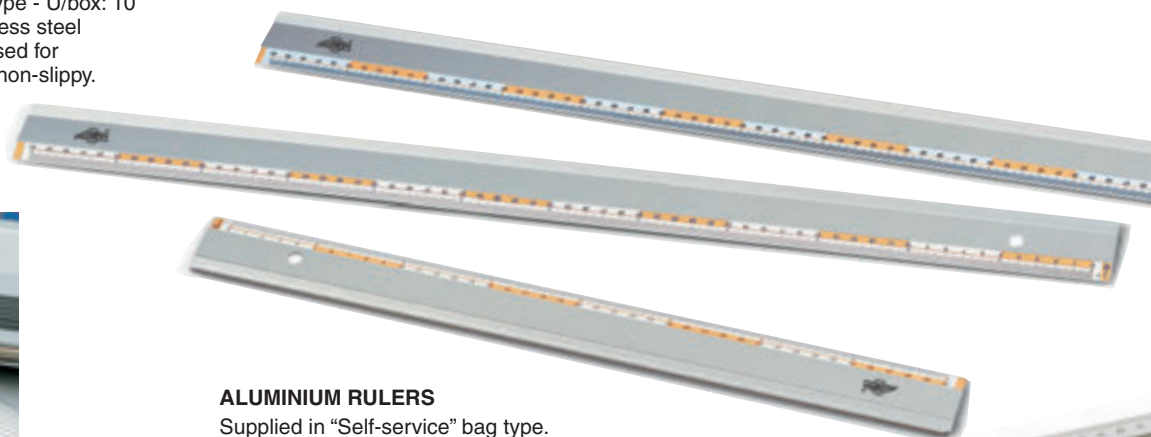

## ALUMINIUM RULERS

Supplied in "Self-service" bag type.

- Ref. 24920 - Ruler 20 cm
- Ref. 24930 - Ruler 30 cm
- Ref. 24940 - Ruler 40 cm
- Ref. 24950 - Ruler 50 cm

## HIGH QUALITY ALUMINIUM RULERS

Supplied in "Self-service" bag type. Rulers of 30, 40 and 50 cm have a rubber band non-slippery.

- Ref. 119-15 - Ruler 15 cm - U/box: 20
- Ref. 119-30 - Ruler 30 cm - U/box: 10
- Ref. 119-40 - Ruler 40 cm - U/box: 10
- Ref. 119-50 - Ruler 50 cm - U/box: 10

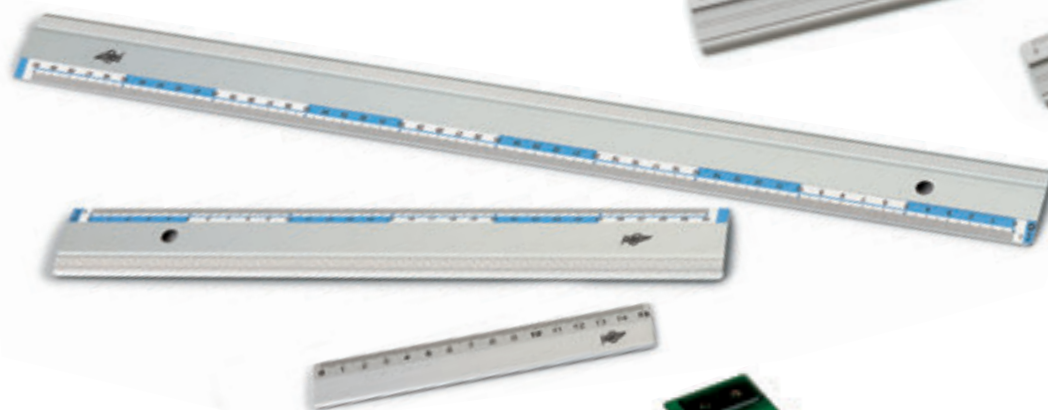
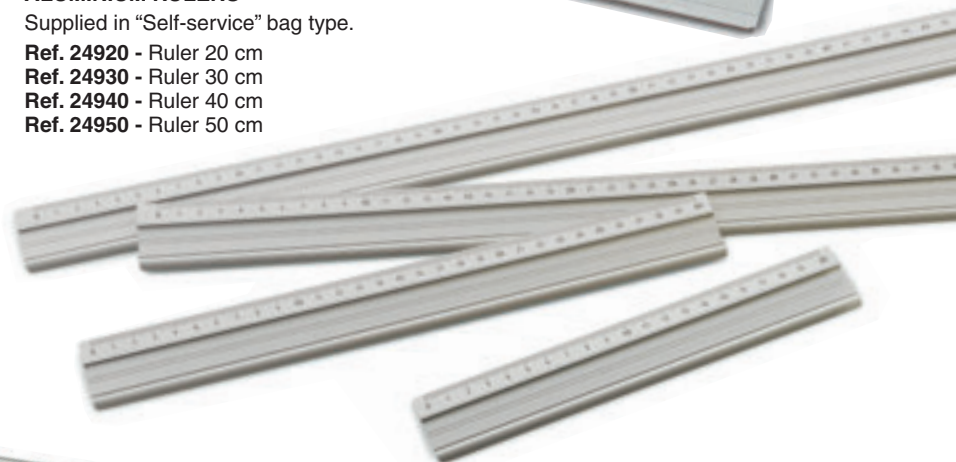

## RULERS TO DRAW PARALLEL LINES 100% Recyclable

Made of plexiglass, mechanized and rectified.  
Supplied in individual bag.

### Ref. 116 - NON GRADUATED

Lengths/cm: 50, 60, 70, 80, 90, 100, 110, 120, 130, 140, 150.  
Transparent colours: clear T and green V.  
U/pack: 2

### Ref. 116G GRADUATED BY THERMO-PRINTING

Lengths/cm: 50, 60, 70, 80, 90, 100.  
Transparent colours: clear T and green V.  
U/pack: 2

## ECONOMICAL RULERS

Certificated according EN 71 Standard  
100% Recyclable

Lengths/cm: 16, 20, 30

### RULERS

Lengths/cm: 20, 30, 40, 50, 60

All the items can be supplied in bulk, in polybag or in "Self-service" bag type, according to the price list.

### DOUBLEDECIMETRES

Lengths/cm: 20

### TRIPLEDECIMETRES

Lengths/cm: 30

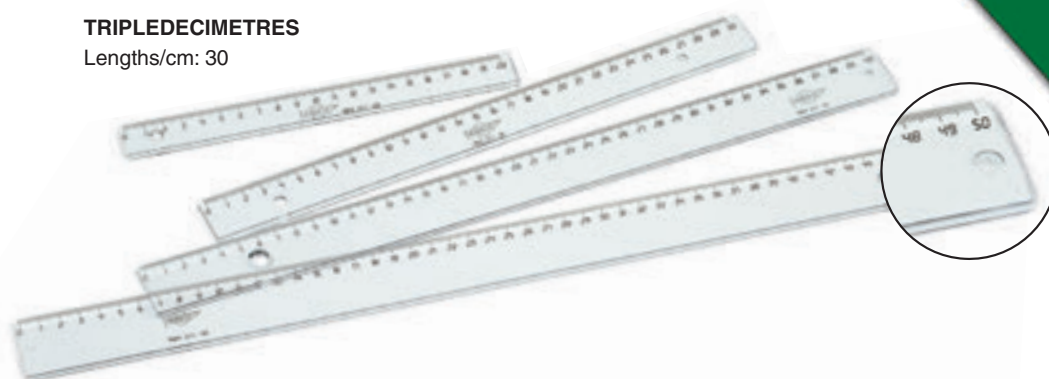





**COMPASSES  
TECHNICAL - 2000 SERIES**  
Certificated according EN 71 Standard  
100% Recyclable

Micrometric. Both legs articulated.  
Supplied in a plastic box.  
With universal adapter and lead box.

**Ref. 101T**

Length of the compasses 165 mm  
It can draw circles up to 280 mm

**Ref. 102T**

Supplied with lengthening bar.  
Length of the compasses 165 mm  
It can draw circles up to 520 mm



**Ref. 201T**

Quick opening mechanism.  
Length of the compasses 165 mm  
It can draw circles up to 280 mm

**Ref. 202T**

Quick opening mechanism,  
with lengthening bar.  
Length of the compasses 165 mm  
It can draw circles up to 520 mm





**RULERS**  
100% Recyclable

**Ref. 900** - 16 cm - 22 mm width.  
U/box: 100

**Ref. 901** - 20 cm - 23 mm width.  
U/box: 100

**Ref. 902** - 20 cm - 32 mm width.  
U/box: 50

**Ref. 903** - 30 cm - 31 mm width.  
U/box: 80

**Ref. 904** - 30 cm - 38 mm width.  
U/box: 50

Colours: white 01, red 03, green 04,  
yellow 05, blue 07.

**Options: We can print  
the customer's logo.**



100% Recyclable

**Ref. 908 - FLYING-DISC**

Diameter: 230 mm - U/carton: 250

**Ref. 909 - EYESHADE**

Measures: 232x178 mm - U/carton: 400

**Ref. 910 - PAY-PAY**

Measures: 180x210 mm - U/carton: 250

**Ref. 907 - ICE-SCRAPER**

Measures: 108x117 mm - U/box: 50

**Ref. 918 - COCKTAIL SPOON**

Measure: 170 mm - U/box: 50

**Ref. 906 - PAPER CLIP**

Measures: 71x149 mm - U/c: 25

Colours: white 01, red 03, green 04,  
yellow 05, blue 07.

**Options: We can print  
the customer's logo.**



WE WOULD THANK YOU INFORM US ABOUT THE  
COLOUR CODE TOGETHER PRODUCT REFERENCE





# Display Line







Ref. 47201

- Portacartel mural A3 vertical
  - Wall mounted upright sign holder, A3
  - Presentoir vertical pour mur A3
- 44,5x30 cm  
U/c: 12



Ref. 47001

- Portacartel mural A4 vertical
  - Wall mounted upright sign holder, A4
  - Presentoir vertical pour mur A4
- 32,4x21 cm  
U/c: 12



Ref. 47101

- Portacartel mural A5 vertical
  - Wall mounted upright sign holder, A5
  - Presentoir vertical pour mur A5
- 24x15 cm  
U/c: 12



Ref. 48000

- Portacartel mural A3 horizontal
  - Wall mounted horizontal sign holder, A3
  - Presentoir horizontal pour mur A3
- 42x33 cm  
U/c: 12



Ref. 46901

- Portacartel mural A4 horizontal
  - Wall mounted horizontal sign holder, A4
  - Presentoir horizontal pour mur A4
- 30x23,5 cm  
U/c: 12





Ref. 48001

- Portacartel de sobremesa en "T" A3 vertical
  - Desk-top upright "T" sign holder, A3
  - Porte-visuel vertical: forme "T" A3
- 43x30x12 cm  
U/c: 6

Ref. 47801

- Portacartel de sobremesa en "T" A4 vertical
  - Desk-top upright "T" sign holder, A4
  - Porte-visuel vertical: forme "T" A4
- 30x21x9,5 cm  
U/c: 12



Ref. 47901

- Portacartel de sobremesa en "T" A5 vertical
  - Desk-top upright "T" sign holder, A5
  - Porte-visuel vertical: forme "T" A5
- 21,5x15x8,3 cm  
U/c: 12



Ref. 684301

- Portacartel de sobremesa en "T" A6 vertical
  - Desk-top upright "T" sign holder, A6
  - Porte-visuel vertical: forme "T" A6
- 15,3x10,7x4,7 cm  
U/c: 12



Ref. 45101

- Portacartel de sobremesa en "T" 1/3 A4 vertical
  - Desk-top upright "T" shape sign holder, 1/3 A4
  - Porte-visuel vertical: forme "T" 1/3 A4
- 21,5x10x8,3 cm  
U/c: 12



Ref. 47701

- Portacartel de sobremesa en "T" A4 horizontal
  - Desk-top horizontal "T" shape sign holder, A4
  - Porte-visuel horizontal: forme "T" A4
- 30x21,5x8,5 cm  
U/c: 12



Ref. 47905

- Portacartel de sobremesa en "T" A5 horizontal
- Desk-top horizontal "T" shape sign holder, A5
- Porte-visuel horizontal: forme "T" A5

21x15,3x7,5 cm  
U/c: 12





Ref. 47601

- Portacartel inclinado de sobremesa A3 vertical
- Desk-top slanted upright sign holder, A3
- Porte-visuel vertical incliné A3  
43x30x10 cm  
U/c: 6



Ref. 47401

- Portacartel inclinado de sobremesa A4 vertical
- Desk-top slanted upright sign holder, A4
- Porte-visuel vertical incliné A4  
30x21x7 cm  
U/c: 12



Ref. 47501

- Portacartel inclinado de sobremesa A5 vertical
- Desk-top slanted upright sign holder, A5
- Porte-visuel vertical incliné A5  
21,5x15x5,3 cm  
U/c: 12

Ref. 480801

- Portacartel inclinado de sobremesa vertical
- Desk-top slanted upright sign holder medium
- Porte-visuel vertical incliné  
9,5x6x4 cm  
U/c: 100





Ref. 47301

- Portacartel inclinado de sobremesa A4 horizontal
  - *Desk-top slanted horizontal sign holder, A4*
  - Porte-visuel horizontal incliné A4
- 30x21,5x7 cm  
U/c: 12



Ref. 47505

- Portacartel inclinado de sobremesa A5 horizontal
  - *Desk-top slanted horizontal sign holder, A5*
  - Porte-visuel horizontal incliné A5
- 21x15,5x5 cm  
U/c: 12



Ref. 480301

- Portacartel inclinado de sobremesa horizontal
  - *Desk-top slanted horizontal sign holder medium*
  - Porte-visuel horizontal incliné
- 9x6,5x3,2 cm  
U/c: 100



- Ref. 76401
- Portafolletos mural A4
- Wall mounted sign holder, A4
- Presentoir pour prospectus A4 pour mur
- 24x23x5 cm
- U/c: 6

- Ref. 76301
- Portafolletos mural A5
- Wall mounted sign holder, A5
- Presentoir pour prospectus A5 pour mur
- 18x17x4 cm
- U/c: 6

- Ref. 76001
- Portafolletos mural 1/3 A4
- Wall mounted sign holder, 1/3 A4
- Presentoir pour prospectus 1/3 A4 pour mur
- 18x11,5x4,7 cm
- U/c: 6



- Ref. 60101
- Portafolletos sobremesa piramidal 3 caras
- Desk-top sign holder pyramidal 3 sides
- Porte-visuels trois faces
- 16x11x10 cm
- U/c: 6

- Ref. 770101
- Portacartel A4 inclinado con compartimento para folletos 1/3 A4 vertical
- Desk-top slanted A4 sign holder with 1/3 A4 brochures
- Presentoir de comptoir incliné, A4, avec boîte pour prospectus 1/3 A4
- 30x21x11 cm
- U/c: 6





Ref. 77501

- Portafolletos sobremesa y mural 1/3 A4
  - Wall mounted and desk-top sign holder, 1/3 A4
  - Presentoir pour prospectus 1/3 A4 pour table et mur
- 20x11,3x8 cm  
U/c: 18



Ref. 77001

- Portafolletos sobremesa y mural A4
  - Wall mounted and desk-top sign holder, A4
  - Presentoir pour prospectus A4 pour table et mur
- 27,5x23,5x10 cm  
U/c: 7

Ref. 74901

- Portafolletos sobremesa y mural A5
  - Wall mounted and desk-top sign holder, A5
  - Presentoir pour prospectus A5 pour table et mur
- 20x17x10 cm  
U/c: 8



Ref. 77701

- Portafolletos 1/3 A4 sobremesa y mural con 4 compartimentos
  - Wall mounted and desk-top sign holder, 1/3 A4 (4 compartments)
  - Presentoir pour prospectus 1/3 A4 (4 compartiments) pour table et mur
- 26x11x15,5 cm  
U/c: 4



Ref. 77441

- Portafolletos A4 sobremesa y mural con 4 compartimentos
  - Wall mounted and desk-top sign holder, A4 (4 compartments)
  - Presentoir pour prospectus A4 (4 compartiments) pour table et mur
- 34,3x23,5x17,5 cm  
U/c: 2



Ref. 77301

- Portafolletos A4 sobremesa y mural con 3 compartimentos
  - Wall mounted and desk-top sign holder, A4 (3 compartments)
  - Presentoir pour prospectus A4 (3 compartiments) pour table et mur
- 32x23,5x16 cm  
U/c: 2



Ref. 77901

- Portafolletos A5 sobremesa y mural con 4 compartimentos
  - Wall mounted and desk-top sign holder, A5 (4 compartments)
  - Presentoir pour prospectus A5 (4 compartiments) pour table et mur
- 25,5x16,5x16 cm  
U/c: 4





- Ref. 778901
- Portanombres de sobremesa
  - Desk-top name holder
  - Porte-nom pour table
- 15x5,5x3 cm  
U/c: 12



- Ref. 48701
- Portanombres de sobremesa
  - Desk-top name holder
  - Porte-nom pour table
- 21x8x8 cm  
U/c: 12



- Ref. 588501
- Placa portanombres mural con imanes y velcro®
  - Wall mounted name holder with magnets and velcro®
  - Support murale fixation avec aimants et velcro®
- 22,5x6 cm  
U/c: 24



- Ref. 70401
- Portatarjetas de sobremesa
  - Desk-top business card holder
  - Porte-cartes visites pour table
- 12,5x5,5x4 cm  
U/c: 24



- Ref. 70101
- Portatarjetas de sobremesa
  - Desk-top business card holder
  - Porte-cartes visites pour table
- 9,5x5x3,5 cm  
U/c: 24



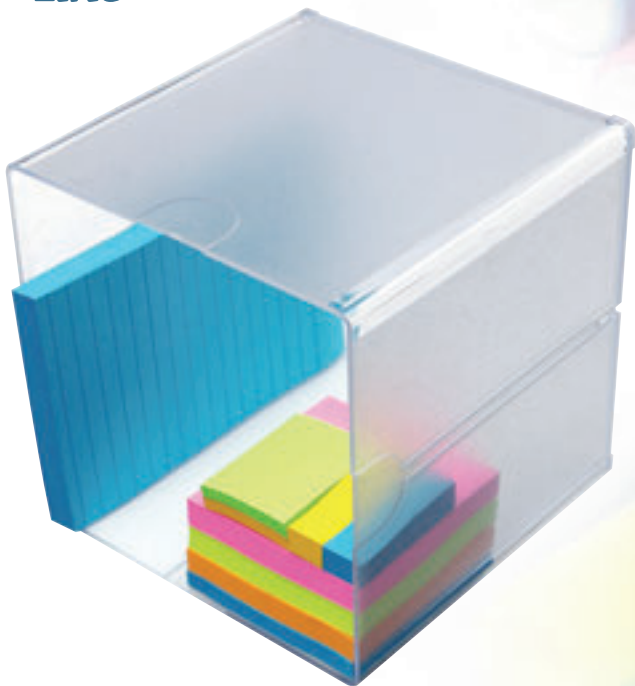

Ref. 350401  
 • Organizador modular hueco  
 • *Hollow cube organizer*  
 • Organisateur modulaire ouvert  
 15,2x15,2x15,2 cm  
 U/c: 6



Ref. 350701  
 • Organizador modular con divisor  
 • *Single shelf divider cube organizer*  
 • Organisateur modulaire avec  
 deux étagères  
 15,2x15,2x15,2 cm  
 U/c: 6



Ref. 350201  
 • Organizador modular divisor  
 en aspa  
 • *"X" shape divider cube organizer*  
 • Organisateur modulaire avec  
 quatre étagères en "X"  
 15,2x15,2x15,2 cm  
 U/c: 6



Ref. 350801  
 • Organizador modular  
 con un cajón  
 de 16,5x14,5x7 cm  
 • *Cube organizer with  
 16,5x14,5x7 cm single drawer*  
 • Organisateur modulaire avec  
 un tiroir de 16,5x14,5x7 cm  
 15,2x15,2x15,2 cm  
 U/c: 6



Ref. 350101

- Organizador modular con dos cajones de 16,5x14,5x7 cm
  - Cube organizer with 16,5x14,5x7 cm two drawers
  - Organisateur modulaire avec deux tiroirs de 16,5x14,5x7 cm.
- 15,2x15,2x15,2 cm  
U/c: 6



Ref. 350301

- Organizador modular con cuatro cajones de 16,5x7x7 cm
  - Cube organizer with 16,5x7x7 cm four drawers
  - Organisateur modulaire avec quatre tiroirs de 16,5x7x7 cm
- 15,2x15,2x15,2 cm  
U/c: 6



Ref. 592901

- Caja para monedas y sugerencias sin llave con espacio personalizable de 16,5x11 cm
  - Small coin and suggestions box unlocked with 16,5x11 cm personalize place
  - Boîte pour monnaie et suggestions sans fermeture, avec espace personnalisable de 16,5x11 cm
- 15,5x11x10 cm  
U/c: 6

Ref. 596901

- Caja para monedas y sugerencias con llave con espacio personalizable de 16,5x11 cm
  - Small coin and suggestions box locked with 16,5x11 cm personalize place
  - Boîte pour monnaie et suggestions avec fermeture, avec espace personnalisable de 16,5x11 cm
- 15,5x11x10 cm  
U/c: 6









**FAIBO is a family Firm which was founded in 1934 by MR. ENRIQUE FAJEDA MERCADER and his wife MRS. ROSA LLORENS VALLMAJOR, as a furniture and school material manufacturer.**

**Along three generations and thanks the effort from the human team which has been cooperating with us in this great development, as well the trust of the customers, suppliers and collaborators allow us to reach our 82 years of history and to be present at 88 countries in five continents.**

**Our great wish and main desire is to follow in the same way, improving and putting all our dedication to satisfy your needs by a personal relationship and high qualified staff to continue being thankful of your confidence.**

**FAIBO is pleased to present you this new catalogue where you can find a wide range of educational, school and stationery products.**

**The purpose that moves FAIBO since 82 years is to attend our customers with seriousness and professionalism.**

**Our commitment is to spare no effort to achieve to be more efficacious, and we can offer you the best service and personalized relationship to continue being thankful of your confidence.**

**All information included in this catalogue must to be only considered as indication.**

**Both pictures and text are capable of suffering variations or not corresponding exactly with product specifications.**

**FAIBO, in your continual desire of innovation, reserve the right to make the modifications that think suitable without notice.**



# OFFICE16



**FAPI GAR ROTXA, S.L.**

C/. Ponent, 25  
17858 LA CANYA  
(SANT JOAN LES FONTS)  
(Girona) ESPAÑA  
Tel. 34-972 29 05 00  
Fax 34-972 29 33 11  
E-mail: [fapi@fapigarrotxa.com](mailto:fapi@fapigarrotxa.com)  
<http://www.fapigarrotxa.com>

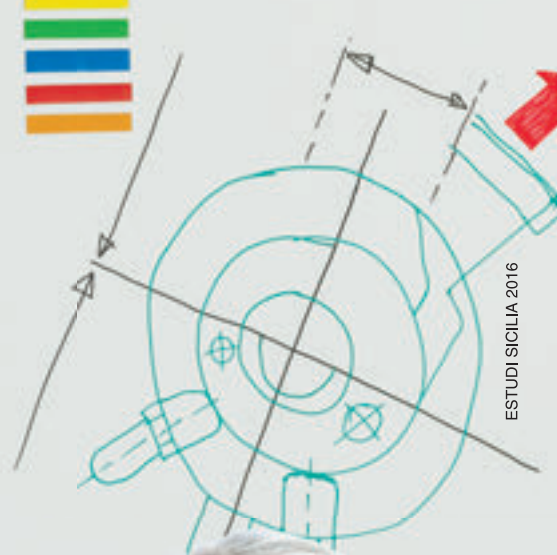

ESTUDI SICILIA 2016